

Reservdelskatalog

Ersatzteilliste

Spare Parts catalogue

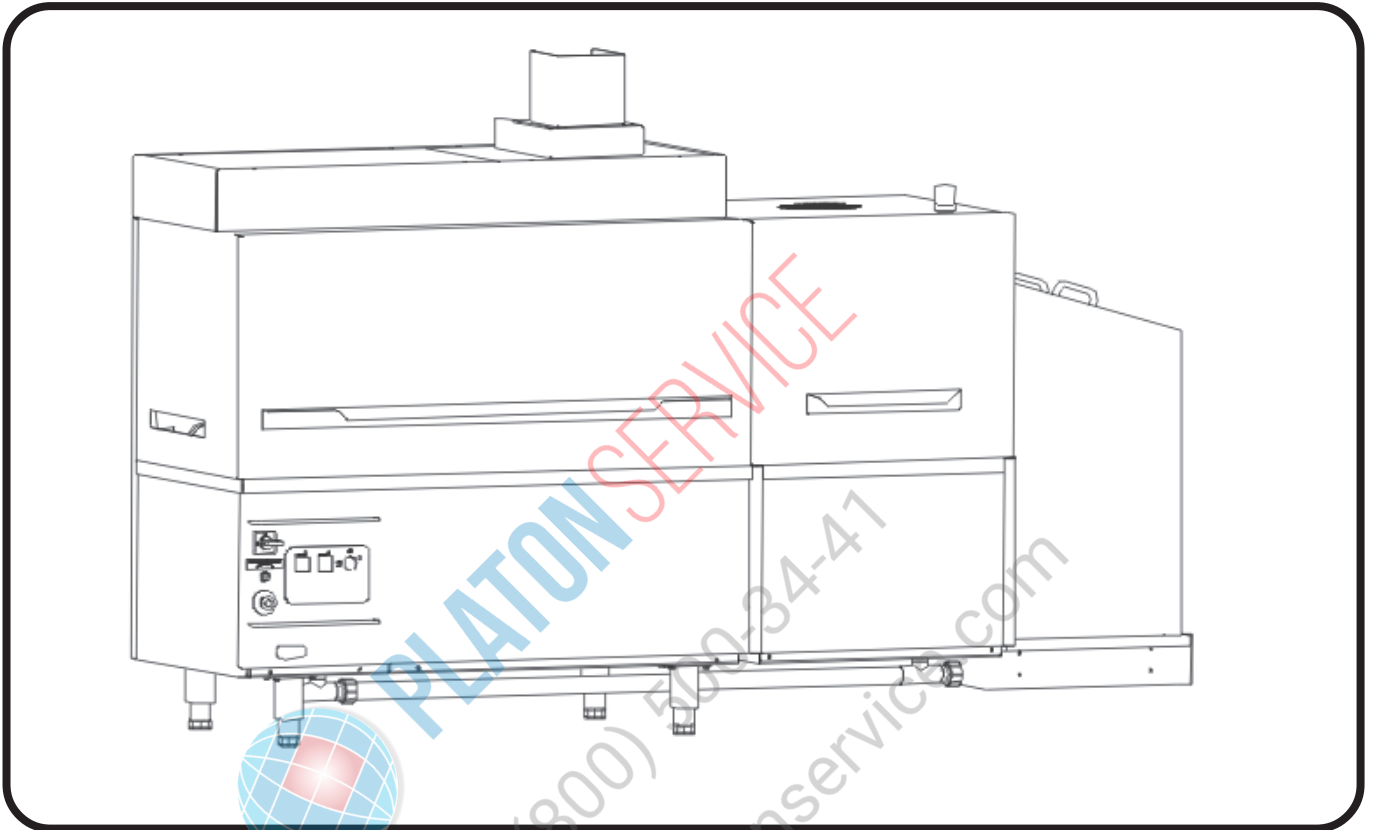

TW1E, ZTW1E
TW1S, ZTW1S

Brickdiskmaskin
Tablettspülmaschine
Tray dishwasher

DOC. NO. **ST0 1618-17**
EDITION **6** 2013.03



PLATONSERVICE

8 (800) 500-34-41

www.platonservice.com

SE	INNEHÅLLSFÖRTECKNING	Sida
----	----------------------	------

• Diskzon	-tank + plåtar	4-7
	-uppvärmning + avlopp och disksystem -version 1	8-11
	-version 2	12-15
• El-detaljer		16-23
• Energipaket	-version 1	24-25
	-version 2	26-27
• Torktzn	-stativ + plåtar	28-29
	-fläkt + avlopp +drivning	30--31
• Brickakumulatör		32-33
• Ånguppvärmd maskin	-uppvärmning + el-detaljer	34-41
• Fästelement		42-44

GB	TABLE OF CONTENTS	Page
----	-------------------	------

• Wash zone	-tank + plates	4-7
	-heating + drain and wash system -version 1	8-11
	-version 2	12-15
• Elektric Parts		16-23
• Energy saving device	-version 1	24-25
	-version 2	26-27
• Drying zone	-stand + plates	28-29
	-fan + drain + feeding	30-31
• Tray accumulator		32-33
• Steam heated machine	-heating + electric parts	34-41
• Attachment elements		42-44

DE	INHALTSVERZEICHNIS	Seite
----	--------------------	-------

• Spülezone	-Tank + Bleche	4-7
	-Erwärmung + Ablauf und Spülsystem -version 1	8-11
	-version 2	12-15
• Electriche teile		16-23
• Wärmerückgewinnung	-version 1	24-25
	-version 2	26-27
• Trockenzone	-Gegtel + Bleche	28-29
	-Gebläse + Ablauf + Zuführung	30-31
• Tablettakkumulatör		32-33
• Dampfbeheiz Maschine	-Erwärmung + Electriche teile	34-41
• Befestigungsteile		42-44

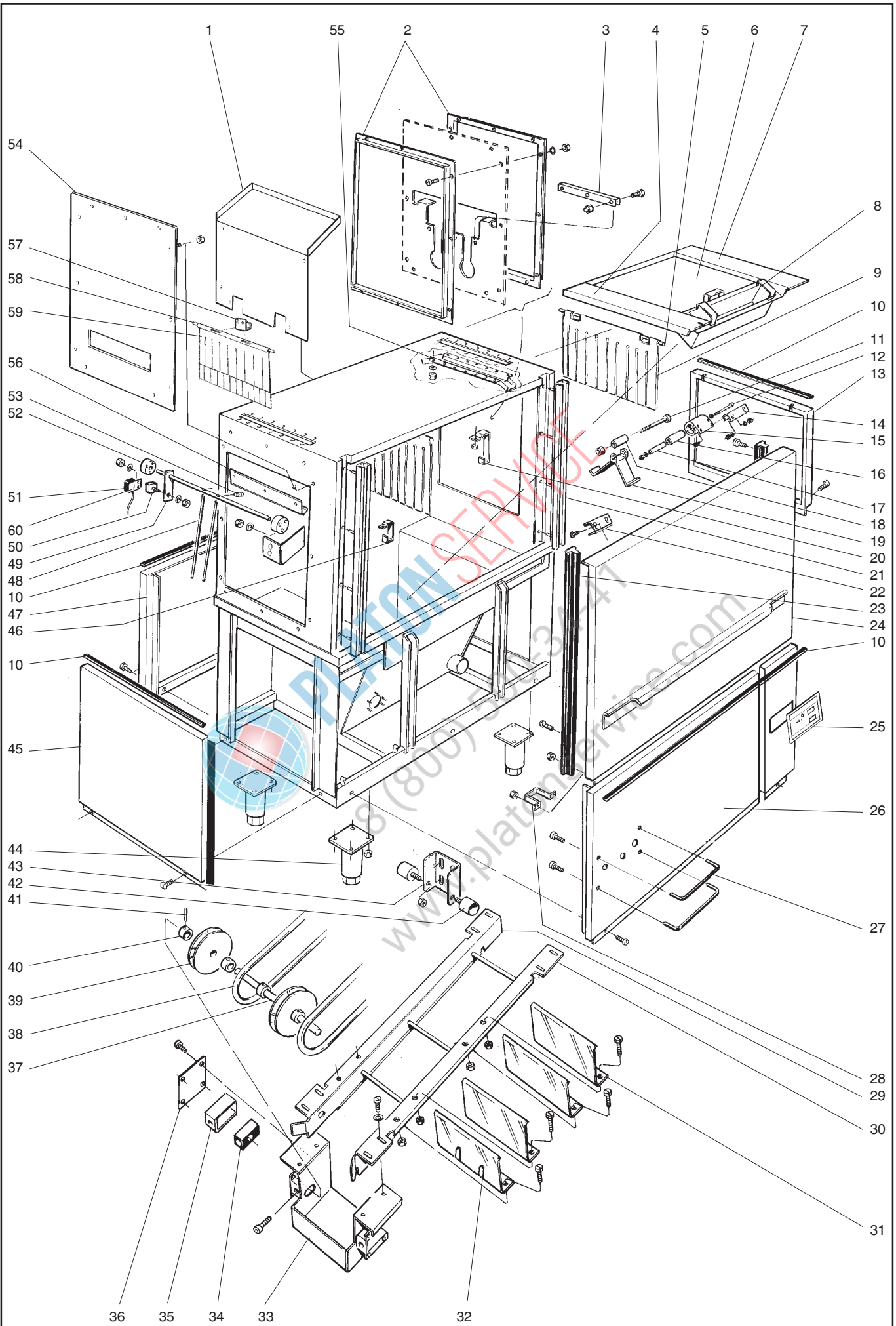

ILLUSTRATION 21633

Diskzon, tank + plåtar
Wash zone, tank + plates
Spülezone, Tank + Bleche

Illustration 21633

Utgåva
Edition
Ausgabe
5

Månad
Month
Monat
01

År
Year
Jahr
2013

Pos.	Antal Quantity Anzahl	Art.nr Art. no Art. Nr	Benämning	Description	Bezeichnung	Anm. Notes Anm.
1	1	ST0 24 87-00	Avrinningsplåt	Drainage plate	Abflussplatte	
2	2	ST0 15 44-00	Dockningsram	Connection profile	Dockningprofil	3).
3	1	ST0 24 37-00	Skarvplåt	Extension plate	Verbindningsplatte	3).
4	1	491 33 24-00	Sidoplåt vänster	Side plate left	Seitenplatten links	
5	2	482 76 03-03	Gardin axel	Curtain shaft	Vorhangachse	
6	1	482 50 04-00	Silplåt	Side plate	Seitenplatten	
7	1	491 33 25-00	Sidoplåt	Side plate	Seitenplatten	
8	1	482 26 28-00	Silkorg	Strainer box	Siebkorb	
9	2	491 32 66-00	Gardin	Curtain	Vorhang	
10	xx m	87 33 30-240	Tättningslist	Sealing strip	Dichtungleiste	
11	1	725 23 86-40	Skruv	Screw	Schraube	3). M6X80 RFR
	1	725 24 65-45	Skruv	Screw	Schraube	4). M8X70 RFR
12	2	725 24 65-45	Skruv	Screw	Schraube	M8X70 RFR
13	2	491 32 81-00	Täckplåt	Cover plate	Deckelplatte	
14	2	482 45 87-00	Fjäderfäste	Spring retainer	Federträger	
15	2	482 25 28-04	Luckfjäder	Spring	Klappenfeder	
16	2	482 25 27-00	Rulle	Pulley	Rolle	
17	2	478 56 10-01	Distans	Spacer	Distanz	
18	1	478 56 10-01	Distansrör	Spacer pipe	Distanzrohr	
19	1	ST0 15 21-00	Luckstopp	Door latch	Türsperre	2).
20	2	491 32 38-00	Gardinfäste	Curtain attachment	Vorhangbefestigung	
21	2	ST0 14 47-00	C-list	C-strip	C-Leiste	
22	2	499 80 84-00	Dörr stopp	Dorr stop	Klapperstop	
23	2	491 32 63-00	Glidlist	Slide strip	Gleitprofil	
24	1	491 32 60-00	Frontlucka	Front door	Tür, vorderseite	
25	1	491 32 88-00	Panel	Panel	Verkleidung	3).
26	1	ST0 35 11-00	Täckplåt front	Cover plate, front	Deckelplatte, vorderseite	5).
	1	ST0 96 02-00	Täckplåt front	Cover plate, front	Deckelplatte, vorderseite	6).
27	2	491 33 07-00	Skyddsbygel	Protective clamp	Schutzbügel	5).
	2	ST0 96 78-00	Skyddsbygel	Protective clamp	Schutzbügel	6).
28	1	491 32 41-00	Bygel	Clamp	Bügel	
29	1	ST0 14 35-00	Gejd	Guide	Führungsleiste	
30	1	ST0 14 34-00	Gejd	Guide	Führungsleiste	
31	3	ST0 20 71-01	Stänkskydd	Splash shield	Spritzschutz	
32	1	ST0 20 71-00	Stänkskydd	Splash shield	Spritzschutz	
33	1	ST0 14 13-00	Inmatningsvagg	Feeding cradle	Zuführauflage	

1). T.o.m 2003 vecka 46

Up to 2003 week 46

Zu 2003 Wochen 46

2). Fr.o.m 2003 vecka 47

From 2003 week 47

Ab. 2003 Wochen 47

3). Till 2008.35

To 2008.35

Zu 2008.35

4). Fr.o.m 2008.36

From 2008.36

Ab 2008.36

5). Till 2012.16

To 2012.16

Zu 2012.16

6). Fr.o.m 2012.17

From 2012.17

Ab 2012.17

Fet stil = Ändring

Bold print = Change

Fettdruck = Änderung

7). **Vänstermatad maskin**

Left hand fed machine

Links Richtung

8). **Högermatad maskin**

Right hand fed machine

Rechts Richtung

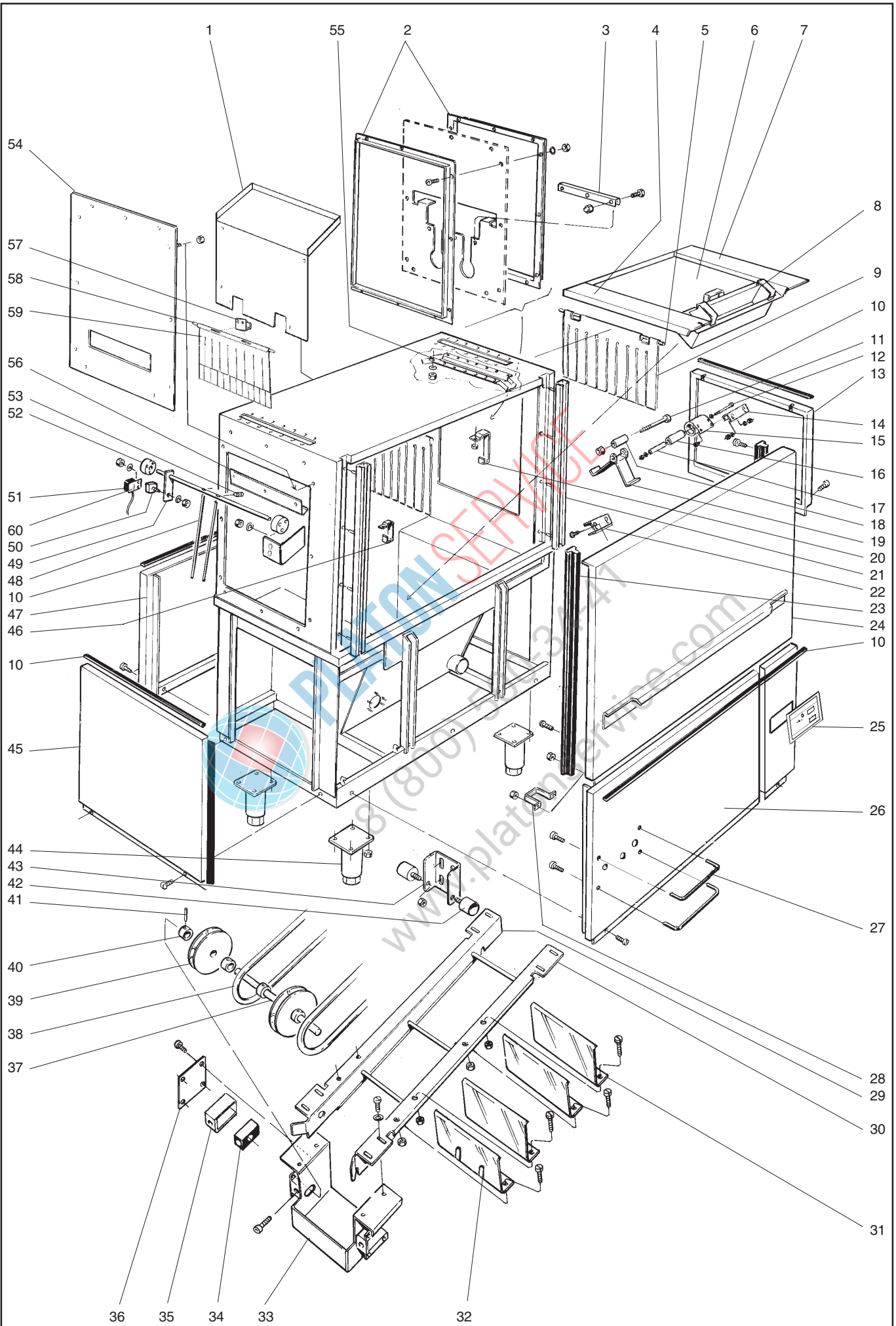

ILLUSTRATION 21633

Diskzon, tank + plåtar
Wash zone, tank + plates
Spülezone, Tank + Bleche

Illustration 21633

Utgåva
Edition
Ausgabe
5

Månad
Month
Monat
01

År
Year
Jahr
2013

Pos.	Antal Quantity Anzahl	Art.nr Art. no Art. Nr	Benämning	Description	Bezeichnung	Anm. Notes Anm.
34	2	ST0 14 31-00	Lagring	Bearing	Lagerung	
35	2	428 07 11-00	Lagringsfäste	Bearing attachment	Lagerungsbefestigung	
36	2	ST0 14 17-00	Täcklock	Cover lid	Deckel	
37	1	428 07 07-00	Axel	Shaft	Asche	
38	9,5	491 36 82-00	Rundrem	Cord	Rundlaufreimen	L=4550x2
39	2	491 37 12-00	Rundremshjul	Cord wheel	Rundlaufreimenrad	3).
	2	ST0 45 62-00	Rundremshjul	Cord wheel	Rundlaufreimenrad	4).
40	4	482 37 08-00	Stoppring	Retaining ring	Halterring	
41	4	89 01 42-033	Stoppskruv	Retaining screw	Sperschraube	3).
42	2	520 27 95-00	Rulle kpl.	Pully cpl.	Rolle kpl.	
43	1	ST0 15 31-00	Hjulkonsol	Wheel bracket	Radhalterung	
44	4	482 25 52-00	Fot	Foot	Fuss	1).
	4	855 64 90-00	Fot	Foot	Fuss	2).
45	1	ST0 24 10-00	Täckplåt	Cover plate	Deckelplatte	
46	2	ST0 15 29-00	Gardin fäste	Curtain attachment	Vorhangbefestigung	
47	1	491 32 80-00	Täckplåt bak	Cover plate, rear	Deckelplatte, rüch	1).
	1	ST0 21 91-00	Täckplåt bak Vänster	Cover plate, rear left	Deckelplatte, rüch Links	2).
	1	ST0 21 92-00	Täckplåt bak Höger	Cover plate, rear Right	Deckelplatte, rüch rechts	2).
48	2	462 16 19-11	Pinne	Dowel	Splint	
49	1	ST0 24 05-00	Grind	Gate	Gittertür	
50	1	461 13 78-02	Magnet	Magnet	Magnet	
51	1	476 06 64-00	Magnetbrytare	Magn. cont. Switch	Magnetausschalte	7).
	1	476 06 64-01	Magnetbrytare	Magn. cont. Switch	Magnetausschalte	8).
52	2	481 72 89-00	Lager	Bearing	Lager	
53	2	728 83 21-09	Stoppskruv	Stop screw	Sperschraube	M5X6 RFR
54	1	428 07 26-00	Täckplåt	Cover plate	Deckelplatte	
55	1	482 60 78-00	Droppskena	Drip guard	Tropfschutz	
56	1	ST0 20 72-00	Droppplåt	Drip plate	Tropfplatte	
57	2	ST0 31 72-00	Gardin fäste	Curtain attachment	Vorhangbefestigung	
58	1	482 76 03-01	Gardin axel	Curtain shaft	Vorhangachse	
59	1	490 15 11-00	Gardin	Curtain	Vorhang	
60	1	481 99 42-00	Fäste	Attachment	Befestigung	

- | | | | |
|------------|----------------------------|----------------------------------|------------------------|
| 1). | T.o.m 2003 vecka 46 | Up to 2003 week 46 | Zu 2003 Vochen 46 |
| 2). | Fr.o.m 2003 vecka 47 | From 2003 week 47 | Ab. 2003 Vochen 47 |
| 3). | Till 2008.35 | To 2008.35 | Zu 2008.35 |
| 4). | Fr.o.m 2008.36 | From 2008.36 | Ab 2008.36 |
| 5). | Till 2012.16 | To 2012.16 | Zu 2012.16 |
| 6). | Fr.o.m 2012.17 | From 2012.17 | Ab 2012.17 |
| 7). | Vänstermatad maskin | Left hand fedded machine | Links Richtung |
| 8). | Högermatad maskin | Right hand fedded machine | Rechts Richtung |

Fet stil = Ändring
Bold print = Change
Fettdruck = Änderung

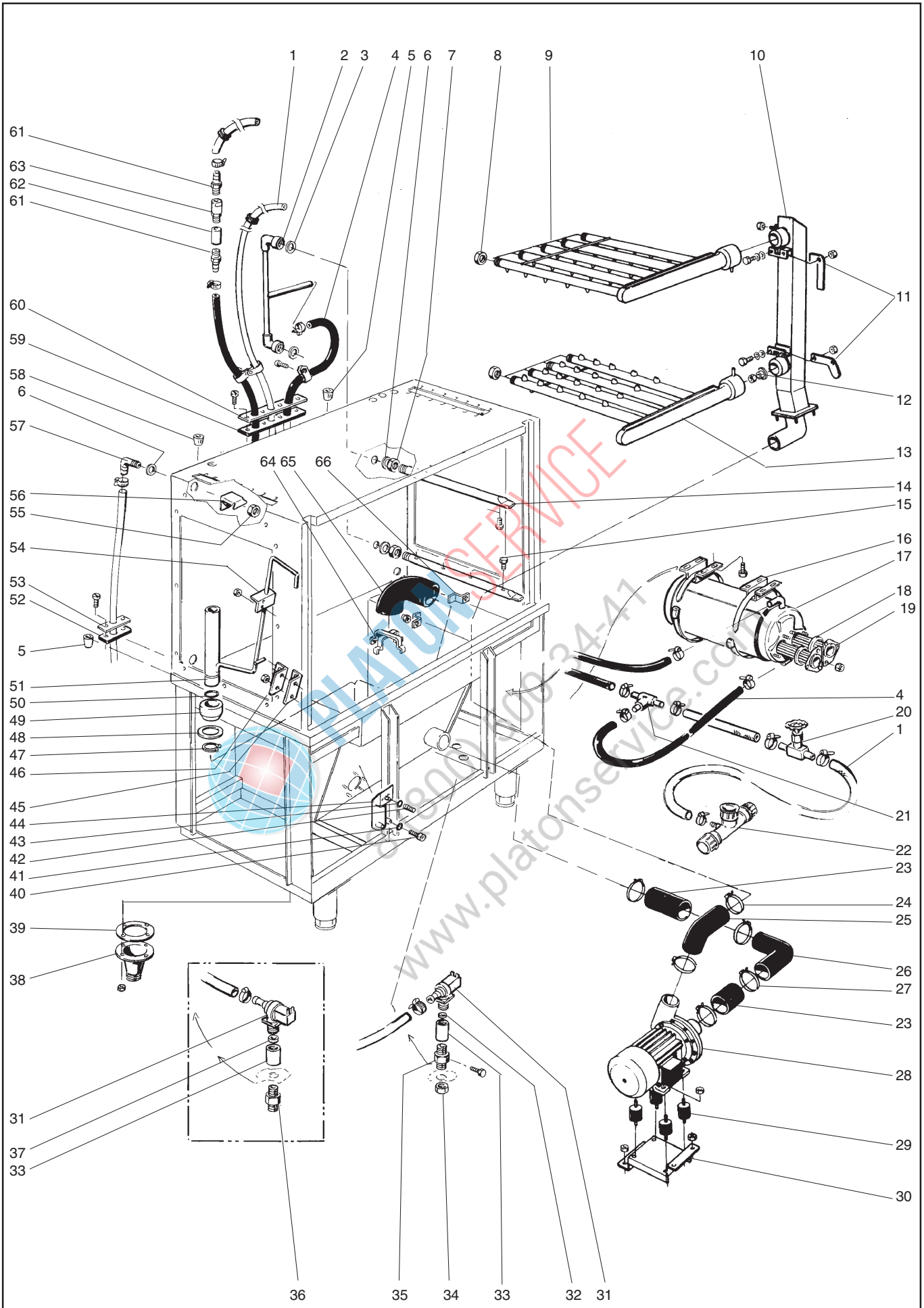

ILLUSTRATION 21631

Disktank, uppvärmning + avlopp Version 1
 Wash zone, heating + drain, wash system Version 1
 Spülezone, Erwärmung + Ablauf, Spülsystem Version 1

Illustration 21631

Utgåva
Edition
Ausgabe
2

Månad
Month
Monat
01

År
Year
Jahr
2013

Pos.	Antal Quantity Anzahl	Art.nr Art. no Art. Nr	Benämning	Description	Bezeichnung	Anm. Notes Anm.
1	x	552 00 11-00	Slang, Röd	Hose, Red	Schaluch, Rot	1/2"
2	2	ST0 14 57-00	rör kpl.	Pipe cpl.	Rohr komplett	
3	2	552 21 10-03	Packning	Gasket	Dichtung	
4	x	552 00 13-00	Slang, Svart	Hose, Black	Schlauch, Schwarz	1/2"
5	2	491 33 11-00	Genomföring	Inlet	Durchführung	
6	1	552 21 10-03	Packning	Gasket	Dichtung	
7	2	743 46 36-07	Rörkoppling	Pipe joint	Rohranschluss	1/2"-18
8	9	741 61 16-24	Huv	Cover	Haube	
9	1	499 68 84-00	Spolarm övre	Rinse system upper	Spülsystem über	
10	1	ST0 14 28-00	Stamrör	Main conduit	Stammleitung	
11	2	482 44 70-00	Låshandtag	Lock handle	Schlosshandgriff	
12	1	482 37 78-00	Strypning	Reducer	Drosselung	
13	1	499 68 83-00	Spolarm under	Rinse system under	Spülsystem unter	
14	2	ST0 15 20-00	Slutspolningrör	Final rinse pipe	Nachspülrohr	
15	4	482 78 46-03	Dys	Nuzzle	Düse	80°, 5 litre
16	2	ST0 14 44-00	Boosterfäste	Attachment	Befestigung	
17	1	0E 5954	Booster	Booster	Booster	
18	2	0E 7620	O-ring	O-ring	O-Ring	
19	2	0E5956	Element	Heating element	Heizkörper	230V, 12kW
20	1	460 15 97-01	Reglerventil	Adjusting valve	Regelventil	
21	1	552 21 74-00	T-slangkoppling	T-Hose nipple	T-Schlauchnippel	1/2"
22	1	482 41 52-00	Avloppsdel	Drain	Ablauf	
23	2	477 92 11-00	Slang	Hose	Schlauch	
24	2	743 28 40-51	Slangklämma	Hose clamp	Schlauchklemme	D=75
25	1	482 42 07-01	Slang	Hose	Schlauch	
26	1	482 59 74-00	Språng	Shed	Sprungfunktion	
27	4	743 28 43-51	Slangklämma	Hose clamp	Schlauchklemme	D=65
28	1	482 77 83-00	Pump	Pump	Pumpe	
29	4	ST0 45 21-00	Dämpare	Vibration absorber	Vibrationsdämpfer	
30	1	482 59 86-00	Pumpkonsol	Console	Konsole	
31	2	482 37 36-00	Magnetventil	Solenoid valve	Magnetventil	24V, 50-60Hz
32	1	482 41 21-20	Strypning	Reducer	Drosselung	20 litre
33	2	741 21 15-20	Muff	Sleeve	Stutzen	3/4"
34	1	741 11 15-20	Mutter	Nut	Mutter	3/4"
35	1	552 21 70-00	Anslutningsnippel	Connection nipple	Anschluss nippel	3/4"
36	1	741 31 15-22	Nippel	Nipple	Nippel	3/4"
37	1	482 41 21-05	Strypning	Reducer	Drosselung	5 litre
38	1	475 77 84-00	Avloppsstos	Drain pipe connection	Ablaufstutzen	
39	1	475 77 83-00	Packning	Gasket	Dichtung	
40	3	552 30 00-04	Skruv	Screw	Schraube	PT-SKX 40x12
41	3	246 09 18-00	Packning	Gasket	Dichtung	
42	1	87 75 25-102	Slang	Hose	Schlauch	
43	1	740 42 09-00	O-ring	O-ring	O-Ring	
44	1	542 60 10-01	Luftklocka	Air tube	Luftrohr	

Fet stil = Ändring
 Bold print = Change
 Fettdruck = Änderung

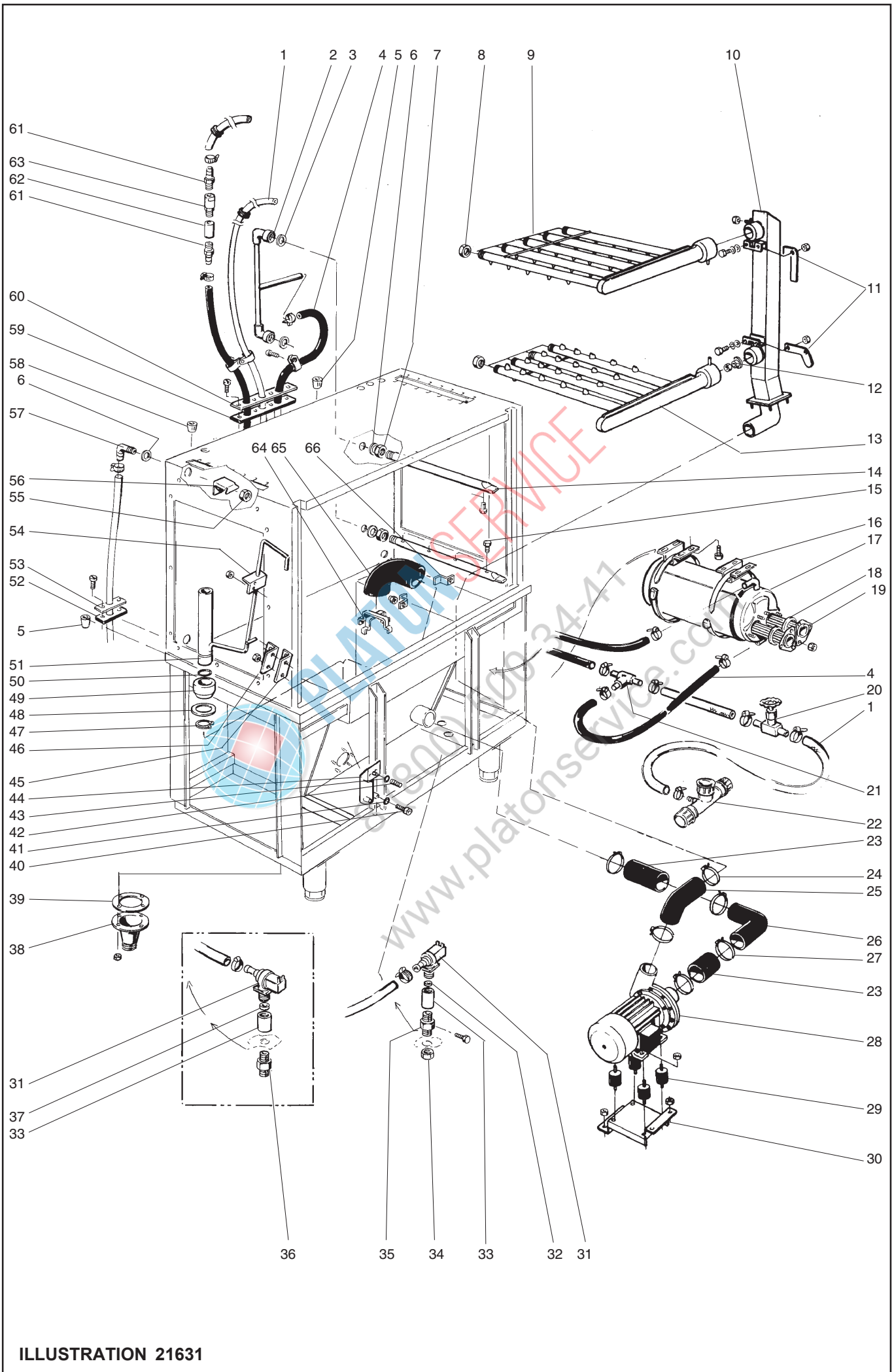

ILLUSTRATION 21631

Disktank, uppvärmning + avlopp Version 1
 Wash zone, heating + drain, wash system Version 1
 Spülezone, Erwärmung + Ablauf, Spülsystem Version 1

Illustration 21631

Utgåva
Edition
Ausgabe
2

Månad
Month
Monat
01

År
Year
Jahr
2013

Pos.	Antal Quantity Anzahl	Art.nr Art. no Art. Nr	Benämning	Description	Bezeichnung	Anm. Notes Anm.
45	1	482 37 34-00	Styrvinkel, vänster	Angular guide, left	Winkelführung, links	
46	1	482 37 33-00	Styrvinkel, höger	Angular guide, right	Winkelführung, rechts	
47	1	735 31 30-07	Spårring	C-clamp	Seegerring	
48	1	475 81 24-02	O-ring	O-ring	O-Ring	
49	1	475 77 83-00	Plugg	Plug	Stöpsel	
50	1	740 44 08-14	O-ring	O-ring	O-Ring	
51	1	482 26 70-00	Avlopps stängning	Drain closer	Abflussabspernung	
52	1	491 32 71-00	Gummigenomföring, kort	Inlet short, rubber	Durchführungs, kurz	
53	1	491 32 73-00	Genomföringsplåt, kort	Leading inplate short	Durchführungsblech, kurz	
54	1	482 37 32-00	L-profil	L-profiled component	L-Profilstück	
55	1	741 11 13-24	Rör mutter	Pipe nut	Rohrmutter	1/2"
56	1	491 32 69-00	Stänklåt	Splash plate	Spritzblech	
57	1	552 21 71-00	Slangnippel	Nipple	Nippel	15x1/2"
58	1	491 33 12-00	Genoföring	Inlet	Durchführung	5-7
59	1	491 32 72-00	Gummigenomföring, lång	Inlet long, rubber	Durchführungs, lang	
60	1	491 32 74-00	Genomföringsplåt, lång	Leading inplate long	Durchführungsblech, lang	
61	2	552 21 75-00	Slangnippel	Nipple	Nippel	15x1/2"
62	2	741 21 13-20	Muff	Sleeve	Stutzen	1/2"
63	1	482 95 27-00	Säkerhetskombination	Safety combination	Sicherheitskombination	
64	1	482 61 80-00	Sugkors	Suctioncross	Ansaugkreuz	
65	1	482 59 85-00	Sugstuds	Suction pipe socket	Saugstutzen	
66	2	482 37 65-00	Fäste	Attachment	Befestigung	

Fet stil = Ändring
 Bold print = Change
 Fettdruck = Änderung

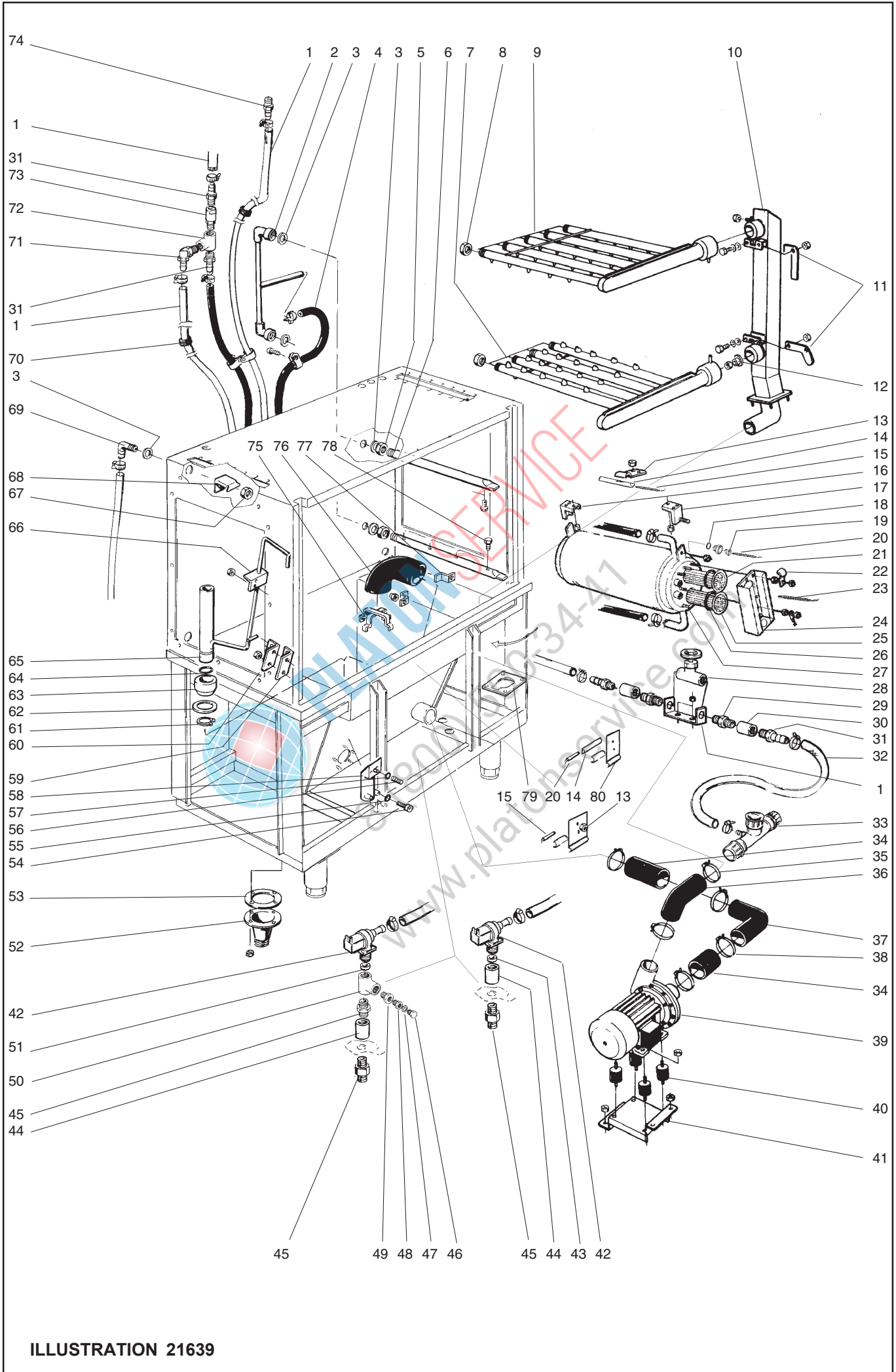

ILLUSTRATION 21639

Disktank, uppvärmning + avlopp Version 2
Wash zone, heating + drain, wash system Version 2
Spülezone, Erwärmung + Ablauf, Spülsystem Version 2

Illustration 21639

Utgåva
Edition
Ausgabe
4

Månad
Month
Monat
01

År
Year
Jahr
2013

Pos.	Antal Quantity Anzahl	Art.nr Art. no Art. Nr	Benämning	Description	Bezeichnung	Anm. Notes Anm.
1	x	552 00 11-00	Slang, Röd	Hose, Red	Schaluch, Rot	1/2"
2	2	ST0 14 57-00	rör kpl.	Pipe cpl.	Rohr komplett	
3	3	552 21 10-03	Packning	Gasket	Dichtung	
4	x	552 00 13-00	Slang, Svart	Hose, Black	Schlauch, Schwarz	1/2"
5	2	743 46 36-07	Rörkoppling	Pipe joint	Rohranschluss	1/2"-18
6	2	ST0 15 20-00	Slutspolningrör	Final rinse pipe	Nachspülrohr	
7	1	499 68 83-00	Spolarm under	Rinse system under	Spülsystem unter	
8	9	741 61 16-24	Huv	Cover	Haube	
9	1	499 68 84-00	Spolarm övre	Rinse system upper	Spülsystem über	
10	1	ST0 14 28-00	Stamrör	Main conduit	Stammleitung	
11	2	482 44 70-00	Låshandtag4901445-00?	Lock handle	Schlosshandgriff	
12	1	482 37 78-00	Strypning	Reducer	Drosselung	
13	2	477 88 69-00	Termostatfäste	Thermostat holder	Thermostathalterung	
14	1	482 60 19-00	Halvrund hylsa	Semicircular sleeve	Halbrunde Hülse	
15	2	481 84 00-05	Termometer	Thermometer	Thermometer	
16	1	482 68 57-00	Boosterfäste bak	Attachment	Befestigung	
17	1	482 68 56-00	Boosterfäste fram	Attachment	Befestigung	
18	1	740 43 03-14	O-ring	O-ring	O-ring	5,3-2,4
19	1	478 04 46-00	Förskruvning	Pipe nipple	Verschraubung	
20	2	475 77 04-02	Termostat	Thermostat	Thermostat	
21	1	482 40 65-02	Element	Heating element	Heizkörper	230/400V, 6kW
22	1	552 21 30-00	Klammer	Clamp	Schelle	
23	1	481 95 01-02	Överhettningsskydd	Overheating protection	Überheiz. schutz	
24	1	482 71 95-00	Element skydd	Protection plate	Schutz blech	
25	1	478 04 08-00	Element	Heating element	Heizkörper	230/400V, 12kW
26	2	740 48 31-05	O-ring	O-ring	O-Ring	
27	1	482 76 75-00	Genomstrmmare kpl.	Booster cpl.	Durchschlauferhitzer	
28	1	460 15 97-01	Reglerventil	Adjusting valve	Regelventil	
29	2	741 38 08-24	Nippel	Nipple	Nippel	1/4"- 1/2"
30	3	741 21 13-20	Muff	Sleeve	Stutzen	1/2"
31	4	ST0 44 84-00	Slangnippel	Nipple	Nippel	15x1/2"
32	1	482 68 92-00	Fäste	Attachment	Befestigung	
33	1	482 41 52-00	Avloppsdel	Drain	Ablauf	
34	2	477 92 11-00	Slang	Hose	Schlauch	
35	2	736 28 40-51	Slangklämma	Hose clamp	Schlauchklemme	D=65
36	1	482 42 07-01	Slang	Hose	Schlauch	
37	1	482 59 74-00	Språng	Shed	Sprungfunktion	
38	6	743 28 43-51	Slangklämma	Hose clamp	Schlauchklemme	D=75
39	1	482 77 83-00	Pump	Pump	Pumpe	
40	4	ST0 45 21-00	Dämpare	Vibration absorber	Vibrationsdämpfer	
41	1	482 78 09-00	Pumpkonsol	Console	Konsole	
42	2	482 37 36-00	Magnetventil	Solenoid valve	Magnetventil	24V, 50-60Hz
43	1	482 41 21-05	Strypning	Reducer	Drosselung	5 litre
44	2	741 21 15-20	Muff	Sleeve	Stutzen	3/4"

Fet stil = Ändring
Bold print = Change
Fettdruck = Änderung

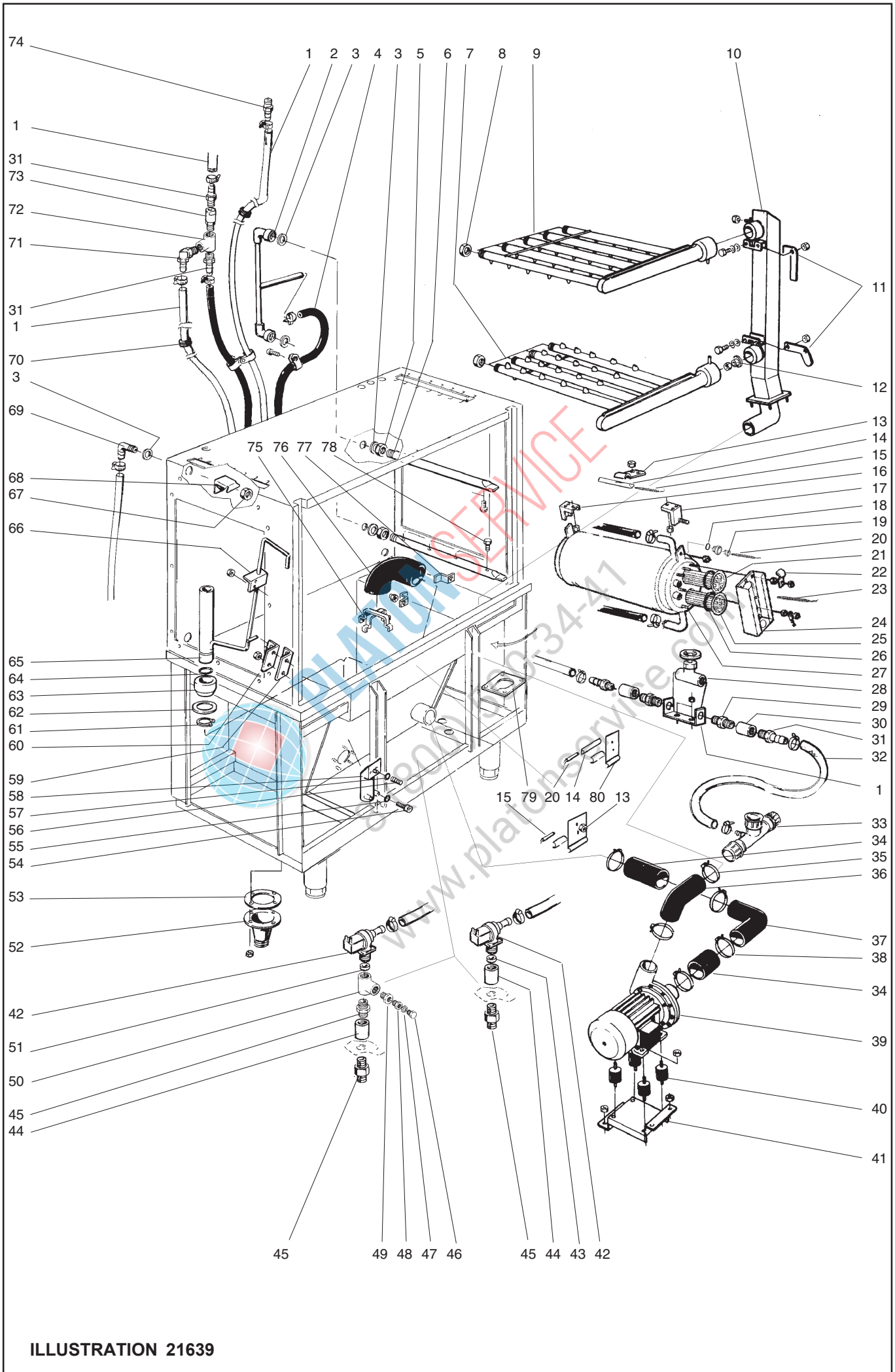

ILLUSTRATION 21639

Disktank, uppvärmning + avlopp Version 2
 Wash zone, heating + drain, wash system Version 2
 Spülezone, Erwärmung + Ablauf, Spülsystem Version 2

Illustration 21639

Utgåva
Edition
Ausgabe
4

Månad
Month
Monat
01

År
Year
Jahr
2013

Pos.	Antal Quantity Anzahl	Art.nr Art. no Art. Nr	Benämning	Description	Bezeichnung	Anm. Notes Anm.
45	1	741 31 15-22	Nippel	Nipple	Nippel	3/4"
46	1	741 52 09-24	Propp	Plug	Pfropfen	1/8"
47	1	552 21 10-00	Packning	Gasket	Dichtung	
48	1	741 41 07-20	Bussning	Bushing	Buchse	1/8"-1/2"
49	1	741 41 14-20	Bussning	Bushing	Buchse	1/2"-3/4"
50	1	742 51 15-20	T-rör	T-tube	T-rohr	3/4"
51	1	482 41 21-20	Strypning	Reducer	Drosselung	20 litre
52	1	475 77 84-00	Avloppsstos	Drain pipe connection	Ablaufstutzen	
53	1	475 77 83-00	Packning	Gasket	Dichtung	
54	3	552 30 00-04	Skruv	Screw	Schraube	PT-SKX 40x12
55	3	246 09 18-00	Packning	Gasket	Dichtung	
56	1	87 75 25-102	Slang	Hose	Schlauch	
57	1	740 42 09-00	O-ring	O-ring	O-Ring	
58	1	542 60 10-01	Luftklocka	Air tube	Luftrohr	
59	1	482 37 34-00	Styrvinkel, vänster	Angular guide, left	Winkelführung, links	
60	1	482 37 33-00	Styrvinkel, höger	Angular guide, right	Winkelführung, rechts	
61	1	735 31 30-07	Spårring	C-clamp	Seegerring	
62	1	475 81 24-02	O-ring	O-ring	O-Ring	
63	1	475 77 83-00	Plugg	Plug	Stöpsel	
64	1	740 44 08-14	O-ring	O-ring	O-Ring	
65	1	482 26 70-00	Avlopps stängning	Drain closer	Abflussabspernung	
66	1	491 33 15-00	Styrvinkel övre	Angular guide, upper	Winkelführung, oben	
67	1	741 11 13-24	Rör mutter	Pipe nut	Rohrmutter	1/2"
68	1	491 32 69-00	Stänklåt	Splash plate	Spritzblech	
69	1	552 21 71-00	Slangnippel	Nipple	Nippel	15x1/2"
70	2	491 33 11-00	Genomföring	Inlet	Durchführung	
71		ST0 44 85 00	Slangnippel vinkel	Hose nipple	Schlauchnippel	
72	1	742 51 13-20	T-rör	T-tube	T-rohr	1/2"
73	1	482 95 27-00	Säkerhetskombination	Safety combination	Sicherheitskombinazion	
74	2	552 21 40-21	Slangnippel	Nipple	Nippel	15x1/2"
75	1	482 61 80-00	Sugkors	Suctioncross	Ansaugkreutz	
76	1	482 59 85-00	Sugstuds	Suction pipe socket	Saugstutzen	
77	2	482 37 65-00	Fäste	Attachment	Befestigung	
78	4	482 78 46-03	Dys	Nuzzle	Düse	80°, 5 litre
79	1	482 34 82-00	Fläns	Flange	Flansche	
80	1	482 61 51-00	Termostatfäste	Thermostat holder	Thermostathalterung	

Fet stil = Ändring
Bold print = Change
Fettdruck = Änderung

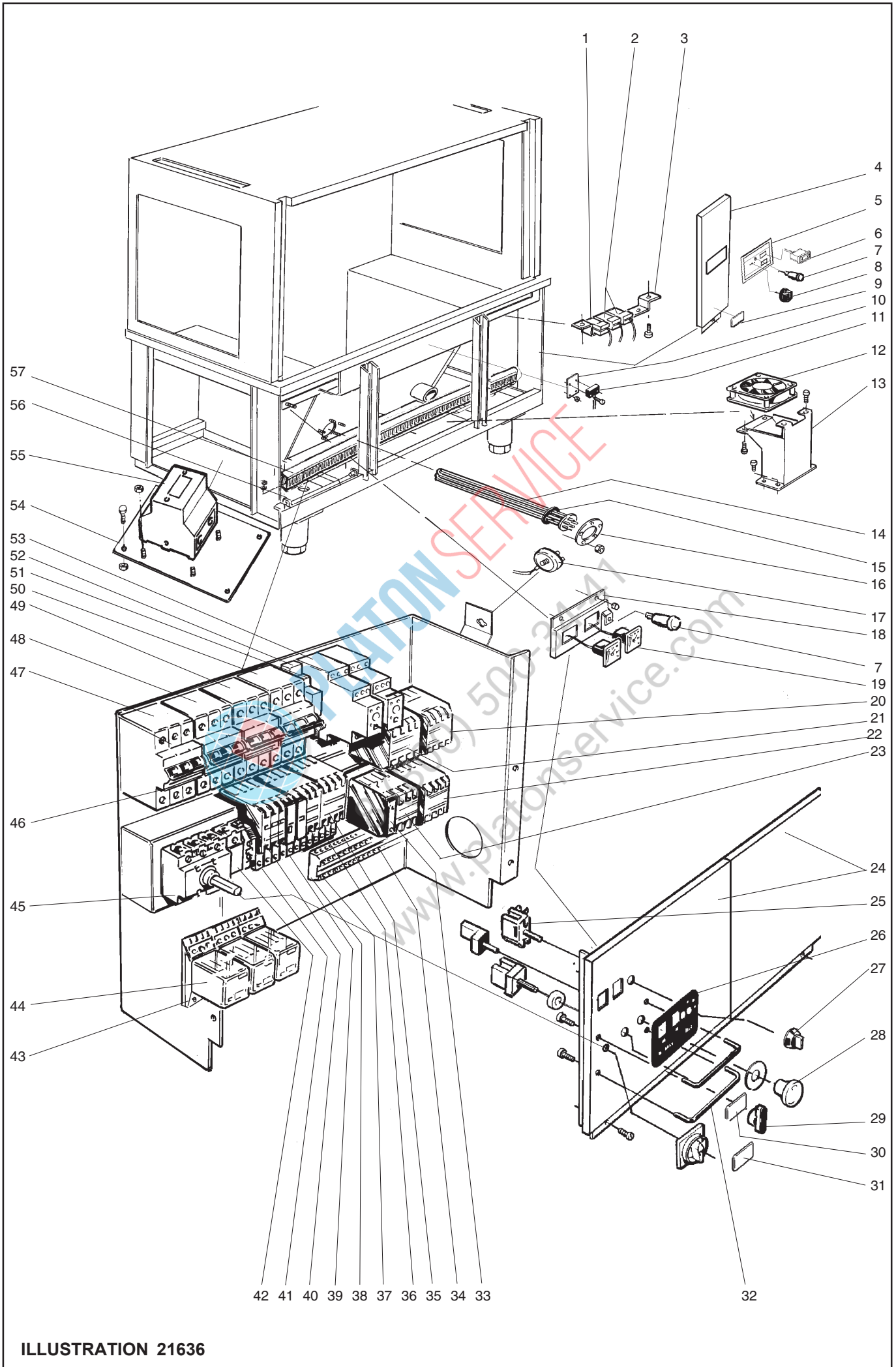

ILLUSTRATION 21636

Elkopponenter Electric components Elektrischekomponenten			Illustration 21636 T.o.m. 2011.12.31, Valid to 2011.12.31, Gültige bis 2011.12.30			Utgåva Edition Ausgabe 3	Månad Month Monat 05	År Year Jahr 2012
Pos.	Antal Quantity Anzahl	Art.nr Art. no Art. Nr	Benämning	Description	Bezeichnung	Anm. Notes Anm.		
1	1	481 95 01-02	Överhettningsskyd	Overheating protection	Überhitzungsschutz			
2	1	475 77 04-02	Termostat	Thermostat	Thermostat			
3	1	482 41 27-00	Termostatfäste	Thermostat socket	Thermostatbefestigung			
4	1	ST2 11 89-00	Front panel Höger	Front panel Right	Deckelplatte vordersiet Recht	2).		
5	1	RT 00605-00	Panel	Panel	Panel	2).		
6	2	482 41 33-02	Termometer	Thermometer	Thermometer	2).		
7	1	482 42 21-00	Lampa, vit	Lamp, white	Lampe, weiss			
8	1	481 74 03-00	Vred	Knob	Drehknopf	2).		
9	1	511 80 05-04	Skylt	Lable	Lable	2).		
10	1	481 99 42-00	Fäste	Attachment	Befestigung			
11	1	476 06 64-00	Magnetbrytare	Magnetic switch	Magnetausschalter			
12	1	477 97 11-00	Fläkt	Fan	Gebläse			
13	1	491 32 59-00	Fläktkanal	Fan channel	Gebläsekanal			
14	1	482 40 64-01	Element	Heating element	Heizkörper	9kW version 1		
	1	482 40 64-00	Element	Heating element	Heizkörper	12kW version 2		
15	1	740 48 31-05	O-ring	O-ring	O-ring			
16	1	478 08 59-00	Elementfläns	Element flange	Körperflansche			
17	1	428 13 00-00	Nivåbrytare	Level control switch	Standsschalter			
18	1	491 32 95-00	Termometerfäste	Attachment, thermomerer	Thermometerbefestigung			
19	2	481 84 00-05	Termometer	Thermometer	Thermometer			
20	1	767 51 11-12	Kontaktor K30	Contactactor K30	Kontaktor K30			
21	1	767 51 14-09	Kontaktor K10	Contactactor K10	Kontaktor K10			
22	1	767 51 11-12	Kontaktor K301	Contactactor K301	Kontaktor K301			
23	1	767 51 14-09	Kontaktor K101	Contactactor K101	Kontaktor K101			
24	1	491 32 83-01	Täckplåt front	Cover plate, front	Deckelplatte, vorderseite	1). 3).		
	1	ST0 35 11-00	Täckplåt front	Cover plate, front	Deckelplatte, vorderseite	1). 4).		
	1	ST0 35 12-00	Täckplåt front	Cover plate, front	Deckelplatte, vorderseite	1). 4).		
	1	ST2 11 88-00	Front panel Vänster	Front panel Left	Deckelplatte vordersiet Links	2).		
25	1	641 60 32-02	Srömställare	Switch	Schalter			
26	1	RT0049902	Panel	Panel	Panel			
27	1	482 68 08-01	Vred	Knobb	Drehknopf			
28	1	428 07 60-00	Nödstopp	Emergency stop	Notstopp			
29	1	482 28 09-00	Strömställare	Switch	Schalter			
30	1	ST0 31 00-01	Skylt	Lable	Lable	SE		
	1	ST0 31 00-02	Skylt	Lable	Lable	GB		
	1	ST0 31 00-03	Skylt	Lable	Lable	DE		
	1	ST0 31 00-04	Skylt	Lable	Lable	FR		
	1	ST0 31 00-05	Skylt	Lable	Lable	NL		
	1	ST0 31 00-06	Skylt	Lable	Lable	FI		
	1	ST0 31 00-07	Skylt	Lable	Lable	NO		
	1	ST0 31 00-08	Skylt	Lable	Lable	DK		
	1	ST0 31 00-09	Skylt	Lable	Lable	IT		
	1	ST0 31 00-15	Skylt	Lable	Lable	ES		

1). TW1

2). ZTW1

3). T.o.m. 2004 vecka 26

4). Fr.o.m. 2004 vecka 27

5). T.o.m. 2009 vecka 04

6). Fr.o.m. 2009 vecka 05

To 2004 week 26

From 2004 week 27

To 2009 week 04

From 2009 week 05

Zu 2004 vochen 26

Ab. 2004 vochen 27

Zu 2009 vochen 04

Ab. 2009 vochen 05

Fet stil = Ändring

Bold print = Change

Fettdruck = Änderung

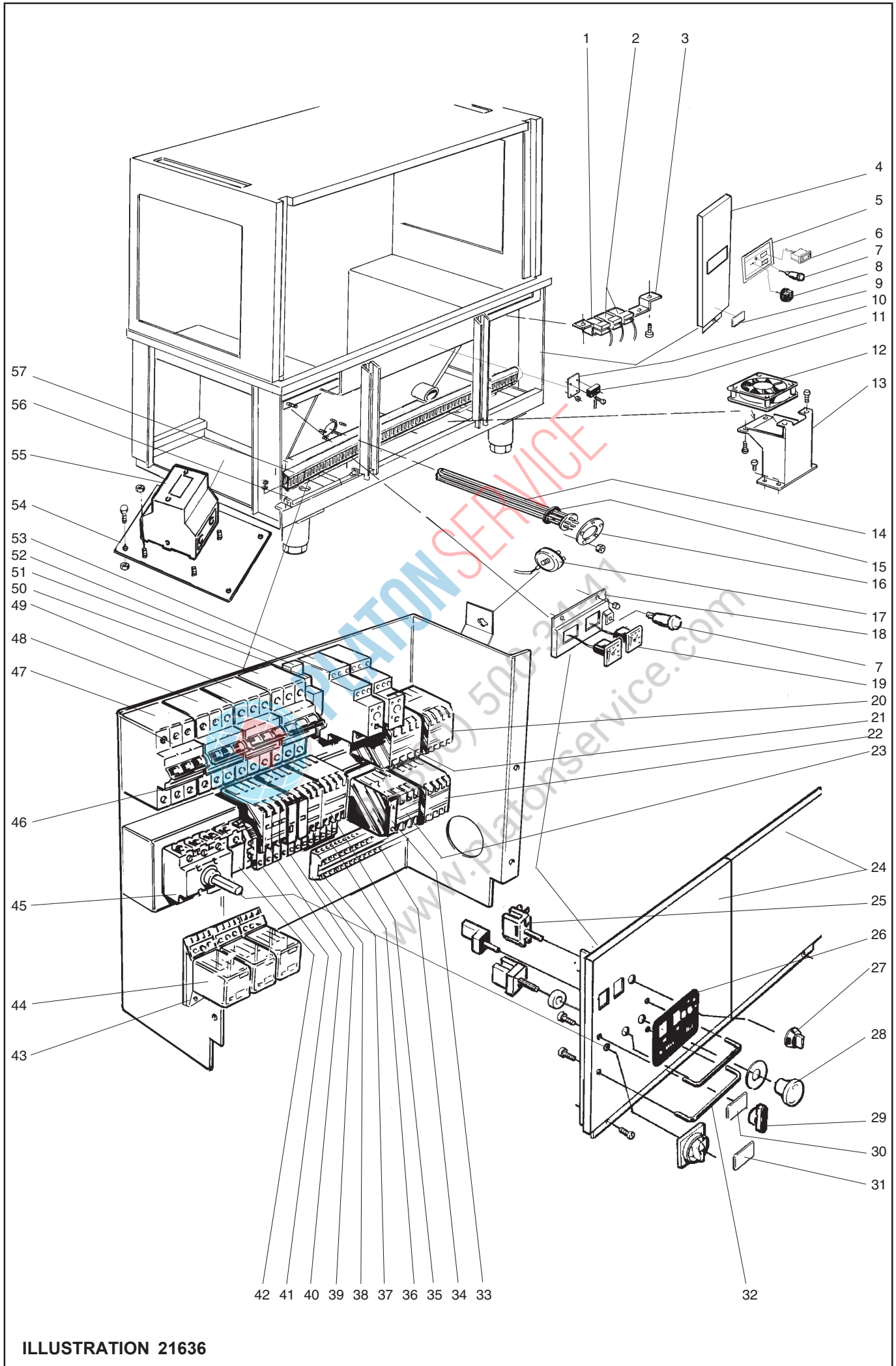

ILLUSTRATION 21636

Elkopponenter Electric components Elektrischekomponenten			Illustration 21636 T.o.m. 2011.12.31, Valid to 2011.12.31, Gültige bis 2011.12.30			Utgåva Edition Ausgabe 3	Månad Month Monat 05	År Year Jahr 2012
Pos.	Antal Quantity Anzahl	Art.nr Art. no Art. Nr	Benämning	Description	Bezeichnung	Anm. Notes Anm.		
31	1	511 61 88-00	Skylt	Lable	Lable	1).		
32	2	ST0 96 78-00	Skyddsbygel	Protection clamp	Schutzbügel			
33	1	767 51 02-92	Hjälpkontakt block	Support contact block	Hilfskontaktblech	NC Röd, red		
34	37	552 22 50-02	Kopplinsplint Grå 4	Terminal block Gray 4	Klemmenbrett			
35	3	767 51 14-09	Kontaktor K1,K4,K7	Contactactor K1,K4,K7	Kontaktor K1,K4,K7	5).		
	3	ST0 27 90-03	Kontaktor K1,K4,K7	Contactactor K1,K4,K7	Kontaktor K1,K4,K7	6).		
36	1	767 61 12-00	Överströmsrelä N7	Overload protection N7	Überlastungsschutz N7	5).		
	1	ST0 28 54-12	Överströmsrelä N7	Overload protection N7	Überlastungsschutz N7	6).		
						8-11 A		
37	2	552 22 54-00	Ändplatta	End plate	Endplatte			
38	4	552 22 55-00	Ändstöd	End support	Stütze			
39	1	767 51 01-92	Hjälpkontakt block	Support contact block	Hilfskontaktblech	NO grön, green		
40	1	767 61 10-00	Överströmsrelä N4	Overload protection N4	Überlastungsschutz N4	5).		
	1	ST0 28 54-07	Överströmsrelä N4	Overload protection N4	Überlastungsschutz N4	6).		
						4-6 A		
41	1	767 61 06-00	Överströmsrelä N1	Overload protection N1	Überlastungsschutz N1	5).		
	1	ST0 28 54-06	Överströmsrelä N1	Overload protection N1	Überlastungsschutz N1	6).		
						0,8-1,2 A		
42	1	552 22 52-06	Kopplinsplint Gul/grön 35	Terminal block Yellow/Green 35	Klemmenbrett Gelb/Grün 35			
43	1	552 21 22-00	Socket 3 pol	Base	Socket			
44	1	552 21 22-01	Relä 3 pol	Relay	Zeitrelais			
45	1	491 45 73-00	Brytare	Switch	Schalter	3).		
	1	ST0 28 60-00	Brytare	Switch	Schalter	4).		
						80A		
46	1	552 55 08-04	Fasskena	Phase bar	Phasenscheine			
47	1	552 22 23-20	Automatsäkring F10	Automatic fuse F10	Automatsicherung F10	20A		
48	1	552 22 23-40	Automatsäkring F30	Automatic fuse F30	Automatsicherung F30	40A		
49	1	552 22 23-20	Automatsäkring F1	Automatic fuse F1	Automatsicherung F1	20A		
50	1	552 22 23-10	Automatsäkring F5	Automatic fuse F5	Automatsicherung F5	10A		
51	1	552 21 23-01	Relä 1 pol	Relay	Zeitrelais	5).		
	1	ST0 59 92-00	Relä 1 pol	Relay	Zeitrelais	6).		
52	1	552 21 23-00	Socket 1 pol	Base	Socket	5).		
	1	ST0 59 91-00	Socket 1 pol	Base	Socket	6).		
53	1	552 22 20-00	Tidrelä	Time relay	Zeitrelais	3).		
	1	ST0 12 42-00	Tidrelä	Time relay	Zeitrelais	4).		
54	1	499 81 51-00	Tafoplåt	Transformer plate	Transformatorblech			
55	1	482 42 20-09	Transformator	Transformer	Transformator	230/24V, 480VA		
56	3	499 81 53-00	Kabelkanal fäste	Attachment	Befestigung			
57	1	87 79 50-205	Kabelkanal	Canal passage	Kablekanal			

1). TW1

2). ZTW1

3). T.o.m. 2004 vecka 26

To 2004 week 26

Zu 2004 vochen 26

4). Fr.o.m. 2004 vecka 27

From 2004 week 27

Ab. 2004 vochen 27

5). T.o.m. 2009 vecka 04

To 2009 week 04

Zu 2009 vochen 04

6). Fr.o.m. 2009 vecka 05

From 2009 week 05

Ab. 2009 vochen 05

Fet stil = Ändring

Bold print = Change

Fettdruck = Änderung

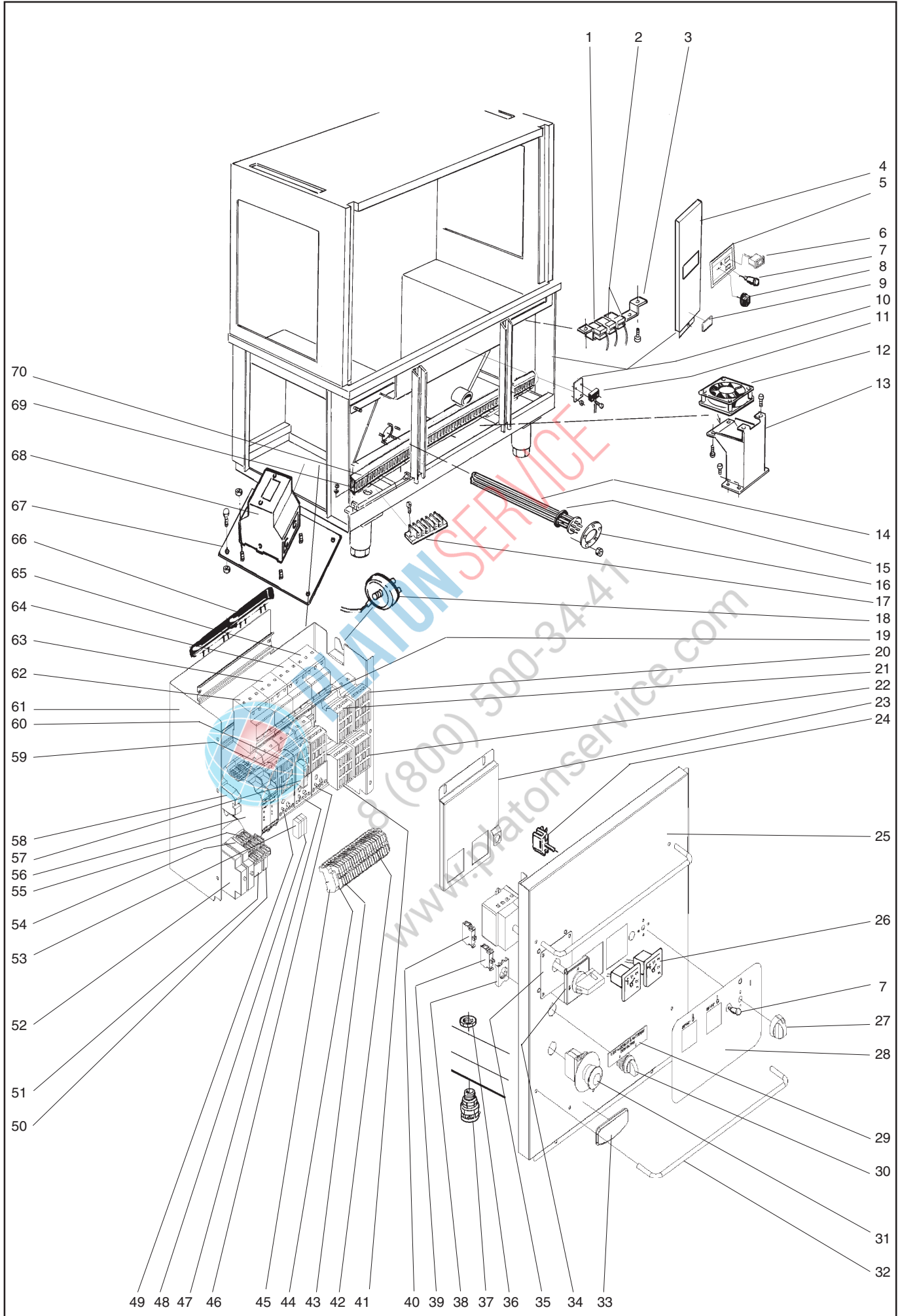

ILLUSTRATION 21645

Elkopponenter Electric components Elektrischekomponenten			Illustration 21645.2 Fr.o.m. 2012.01.01, valid from 2012.01.01, Gilt vom 2012.01.01			Utgåva Edition Ausgabe 2	Månad Month Monat 03	År Year Jahr 2013
Pos.	Antal Quantity Anzahl	Art.nr Art. no Art. Nr	Benämning	Description	Bezeichnung	Anm. Notes Anm.		
1	1	481 95 01-02	Överhettningsskyd	Overheating protection	Überhitzungsschutz			
2	2	475 77 04-02	Termostat	Thermostat	Thermostat			
3	1	482 41 27-00	Termostatfäste	Thermostat socket	Thermostatbefestigung			
4	1	ST2 11 89-00	Front panel Höger	Front panel Right	Deckelplatte vordersiet Recht			
5	1	RT 00605-00	Panel	Panel	Panel			
6	2	482 41 33-02	Termometer	Thermometer	Thermometer			
7	1	482 42 21-00	Lampa, vit	Lamp, white	Lampe, weiss			
8	1	481 74 03-00	Vred	Knob	Drehknopf			
9	1	511 80 05-04	Skylt	Lable	Lable			
10	2	481 99 42-00	Fäste	Attachment	Befestigung			
11	1	476 06 64-00	Magnetbrytare	Magnetic switch	Magnetausschalter			
12	1	477 97 11-00	Fläkt	Fan	Gebläse			
13	1	491 32 59-00	Fläktkanal	Fan channel	Gebläsekanal			
14	1	482 40 64-00	Element	Heating element	Heizkörper	12kW		
15	1	740 48 31-05	O-ring	O-ring	O-ring			
16	1	478 08 59-00	Elementfläns	Element flange	Körperflansche			
17	1	482 41 25-02	Jordskena	Earth-connection bar	Erdverbindungsscheine 1).	3 pol.		
	1	464 28 96-06	Jordskena	Earth-connection bar	Erdverbindungsscheine 2).	7 pol.		
18	1	428 13 00-00	Nivåbrytare	Level control switch	Standswitcher			
19	1	552 55 08-04	Fasskena	Phase bar	Phasenscheine			
20	1	ST0 27 90-02	Kontaktor K30	Contacto K30	Kontaktor K30			
21	1	ST0 27 90-03	Kontaktor K10	Contacto K10	Kontaktor K10			
22	1	ST0 27 90-02	Kontaktor K301	Contacto K301	Kontaktor K301			
23	1	ST0 96 79-00	Termometerfäste	Attachment, thermomerer	Thermometerbefestigung			
24	1	641 60 32-02	Srömsällare	Switch	Schalter			
25	1	ST0 96 02-00	Täckplåt front, Vä	Cover plate, front, left	Deckelplatte, vorderseite			
	1	ST0 35 12-00	Täckplåt front	Cover plate, front	Deckelplatte, vorderseite			
	1	ST2 11 88-00	Front panel Vänster	Front panel Left	Deckelplatte vordersiet Links			
26	2	481 84 00-05	Termometer	Thermometer	Thermometer			
27	1	482 68 08-01	Vred	Knobb	Drehknopf			
28	1	RT0049902	Panel	Panel	Panel			
29	1	ST0 62 12-00	Skylt	Lable	Lable	SE		
	1	ST0 62 12-02	Skylt	Lable	Lable	GB		
	1	ST0 62 12-03	Skylt	Lable	Lable	DE		
	1	ST0 62 12-04	Skylt	Lable	Lable	FR		
	1	ST0 62 12-05	Skylt	Lable	Lable	NL		
	1	ST0 62 12-06	Skylt	Lable	Lable	FI		
	1	ST0 62 12-07	Skylt	Lable	Lable	NO		
	1	ST0 62 12-08	Skylt	Lable	Lable	DK		
	1	ST0 62 12-09	Skylt	Lable	Lable	IT		
	1	ST0 62 12-15	Skylt	Lable	Lable	ES		
30	1	ST0 89 23-00	Strömsällare 2 läges	Switch	Schalter			
31	1	428 07 60-01	Nödstopp	Emergency stop	Notstopp			
32	2	ST0 96 78-00	Skyddsbygel	Protection clamp	Schutzbügel	2 NC		
33	1	511 61 88-00	Skylt	Lable	Lable			

Fet stil = Ändring

Bold print = Change

Fettdruck = Änderung

1). T.o.m 2012 vecka 52

2). Fr.o.m 2013 vecka 01

Up to 2012 week 52

From 2013 week 01

Zu 2012 Vochen 52

Ab. 2013 Vochen 01

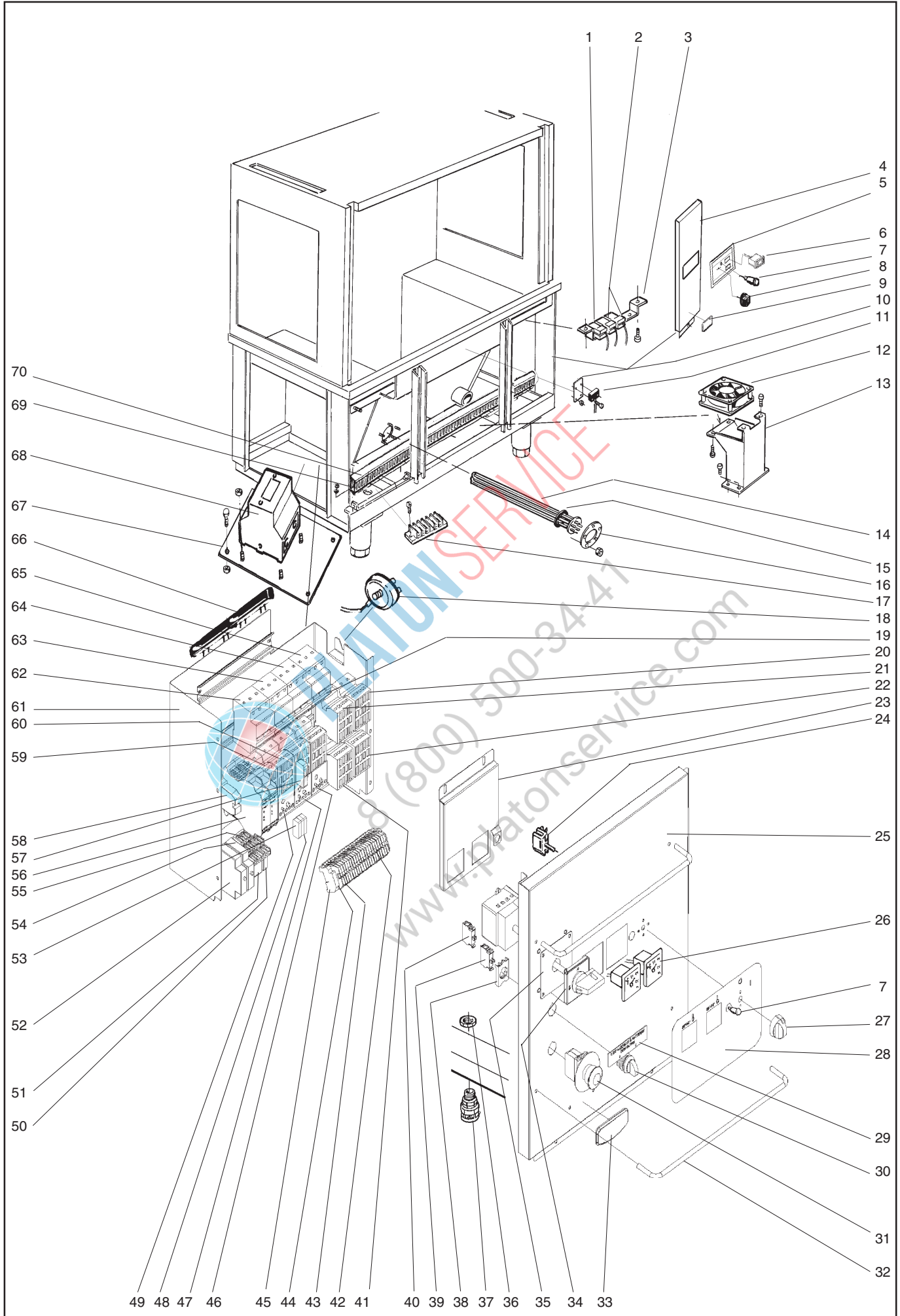

ILLUSTRATION 21645

Elkopponenter Electric components Elektrischekomponenten			Illustration 21645.2 Fr.o.m. 2012.01.01, valid from 2012.01.01, Gilt vom 2012.01.01			Utgåva Edition Ausgabe 2	Månad Month Monat 03	År Year Jahr 2013
Pos.	Antal Quantity Anzahl	Art.nr Art. no Art. Nr	Benämning	Description	Bezeichnung	Anm. Notes Anm.		
34	1	428 04 10-01	Brytare	Switch	Schalter	63A		
35	1	ST0 96 83-00	Brytarplåt	Switch bracket	Schalterbefestigung			
36	1	762 11 14-55	Mutter	Nut	Mutter	Pr47		
37	1	762 21 14-06	Hylsa	Sleeve	Hülse	Pr47		
38	1	ST0 87 71-00	Adapter					
39	1	ST0 87 72-00	Kontakt block	Contact block	Kontakt block	NO, M22-K10		
40	1	ST0 87 74-00	Kontakt block	Contact block	Kontakt block	NC, M22-K01		
41	1	ST0 27 90-03	Kontaktor K101	Contactactor K101	Kontaktor K101			
42	x	552 22 50-02	Kopplinsplint Grå 4	Terminal block Gray 4	Klemmenbrett			
43	1	552 22 52-04	Kopplinsplint Gul/grön 16	Terminal block Yellow/Green 16	Klemmenbrett Gelb/Grün 16			
44	2	552 22 54-00	Ändplatta	End plate	Endplatte			
45	4	552 22 55-00	Ändstöd	End support	Stütze			
46	1	ST0 28 54-12	Överströmsrelä N7	Overload protection N7	Überlastungsschutz N7	8-11 A		
47	1	ST0 28 54-10	Överströmsrelä N4	Overload protection N4	Überlastungsschutz N4	4-6 A		
48	2	767 51 02-92	Hjälpkontakt block	Support contact block	Hilfskontaktblech	NC, HN01		
49	1	ST0 28 54-06	Överströmsrelä N1	Overload protection N1	Überlastungsschutz N1	0,8-1,2 A		
50	1	ST0 93 87-10	Sockel	Base	Sockel	2 pol		
51	1	ST0 93 87-00	Sockel	Base	Sockel	4 pol		
52	2	ST0 12 42-00	Tidrelä	Time relay	Zeitrelais			
53	1	767 51 01-92	Hjälpkontakt block	Support contact block	Hilfskontaktblech	NO, HN10		
54	1	ST0 93 86-00	Relä	Relay	Zeitrelais	4 pol VAC		
55	1	ST0 93 86-10	Relä	Relay	Zeitrelais	2 pol		
56	2	ST0 93 13-00	Säkerhetsrelä	Safety relay	Sicherheitsrelais			
57	1	767 51 01-92	Hjälpkontakt block	Support contact block	Hilfskontaktblech	NO, HN10		
58	1	552 22 52-06	Kopplinsplint Gul/grön 35	Terminal block Yellow/Green 35	Klemmenbrett Gelb/Grün 35			
59	1	ST0 27 90-12	Kontaktor K3	Contactactor K3	Kontaktor K3			
60	x	ST0 27 90-03	Kontaktor K1,K4,K7	Contactactor K1,K4,K7	Kontaktor K1,K4,K7			
61	1	ST0 96 03-00	Elplåt	Connection plate	Anschlussblech			
62	1	552 22 23-20	Automatsäkring F10	Automatic fuse F10	Automatsicherung F10	20A		
63	1	552 22 23-40	Automatsäkring F30	Automatic fuse F30	Automatsicherung F30	40A		
64	1	552 22 23-20	Automatsäkring F1	Automatic fuse F1	Automatsicherung F1	20A		
65	1	552 22 23-10	Automatsäkring F5	Automatic fuse F5	Automatsicherung F5	10A		
66	1	552 55 08-04	Fasskena	Phase bar	Phasenscheine			
67	1	499 81 51-00	Trafoplåt	Transformer plate	Transformatorblech			
68	1	482 42 20-09	Transformator	Transformer	Transformator	230/24V,480VA		
69	3	499 81 53-00	Kabelkanal fäste	Attachment	Befestigung			
70	1	87 79 50-205	Kabelkanal	Canal passage	Kablekanal			

Fet stil = Ändring

Bold print = Change

Fettdruck = Änderung

1). T.o.m 2012 vecka 52

2). Fr.o.m 2013 vecka 01

Up to 2012 week 52

From 2013 week 01

Zu 2012 Vochen 52

Ab. 2013 Vochen 01

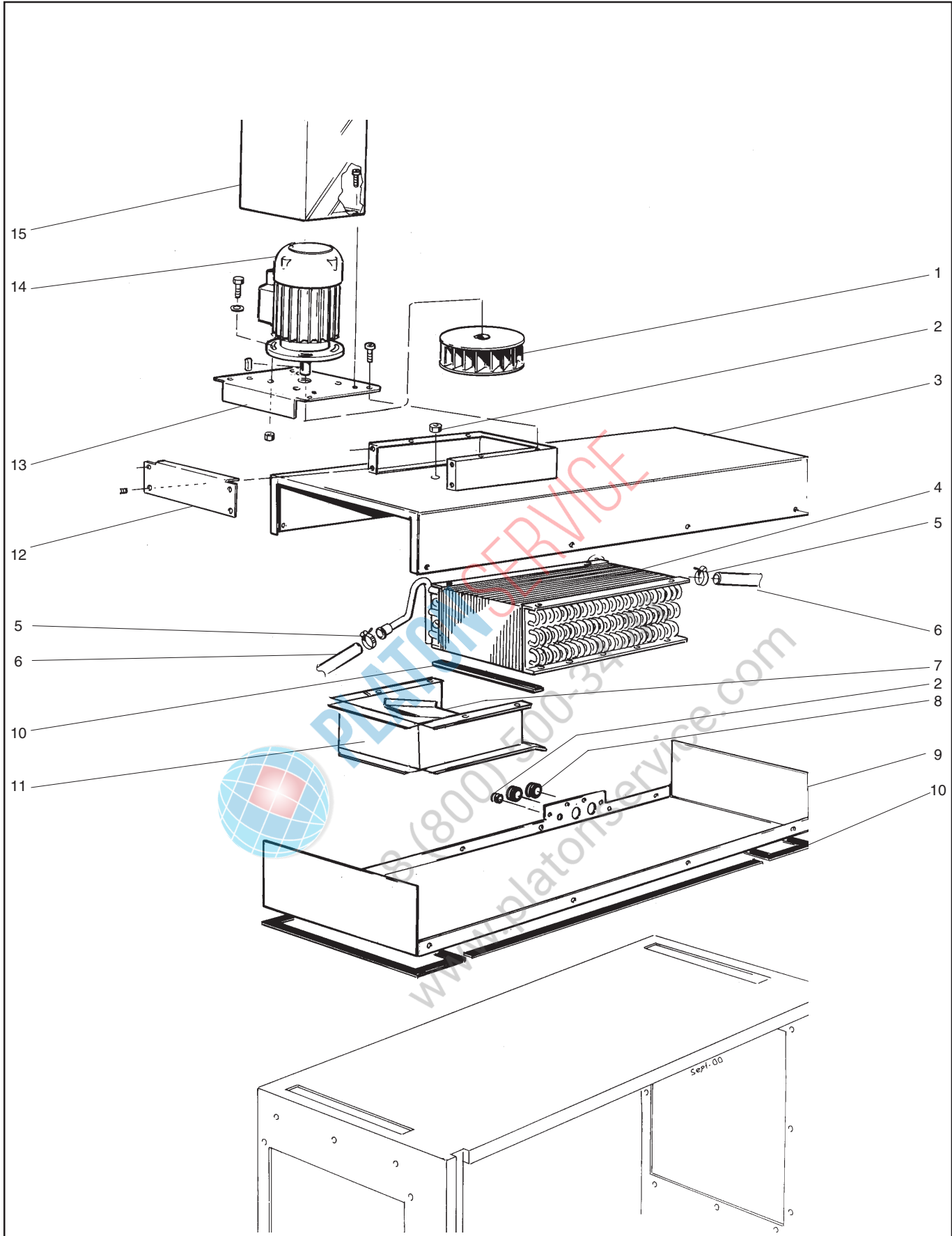

ILLUSTRATION 21635

Kondensbatteri version 1
Condensing unit version 1
Kondensationsbatteri version 1

Illustration 21635

Utgåva
Edition
Ausgabe
2

Månad
Month
Monat
05

År
Year
Jahr
2012

Pos.	Antal Quantity Anzahl	Art.nr Art. no Art. Nr	Benämning	Description	Bezeichnung	Anm. Notes Anm.
1	1	OE5952	Fläkt	Fan	Gebläse	
2	2	762 11 68-00	Genomföring	Inlet	Durchführung	D=8
3	1	ST0 14 53-00	Kondenstak	Top, condensing unit	Dach, kondensation	1).
	1	ST0 14 53-01	Kondenstak	Top, condensing unit	Dach, kondensation	2).
4	1	482 54 44-00	Lamellelement	Lamellar element	Lamellenelement	
5	1	736 28 19-51	Slang klämma	Hose clamp	Schlauchklemme	D=24
6	1	552 00 11-00	Slang	Hose	Schlauch	1/2"
7	1	ST0 23 03-00	Kondensplåt	plate, condensing unit	Blech, kondensation	
8	2	552 20 18-00	Genomföring	Inlet	Durchführung	22X38
9	1	OE5948	Kondenslåda	Condensing box	Kondensationskasten	
10	x	873 30 32-40	List	Strip	Leiste	
11	1	ST0 21 39-00	Ledplåt	Guiding plate	Führungsblech	
12	1	482 55 45-00	Baksida	Rear	Rückseiten	
13	1	W00467701	Panel hölje	Casing panel	Ummatlungspanel	
14	1	OE5951	Fläktmotor	Fan motor	Gebläsemotor	
15	1	OE5970	Hölje	Casing	Ummantelung	



PLATON SERVICE
8 (800) 500-34-47
www.platonservice.com

Fet stil = Ändring
Bold print = Change
Fettdruck = Änderung

1). Vänstermatad maskin
2). Högermatad maskin

Left hand feeded machine
Right hand feeded machine

Links Richtung
Rechts Richtung

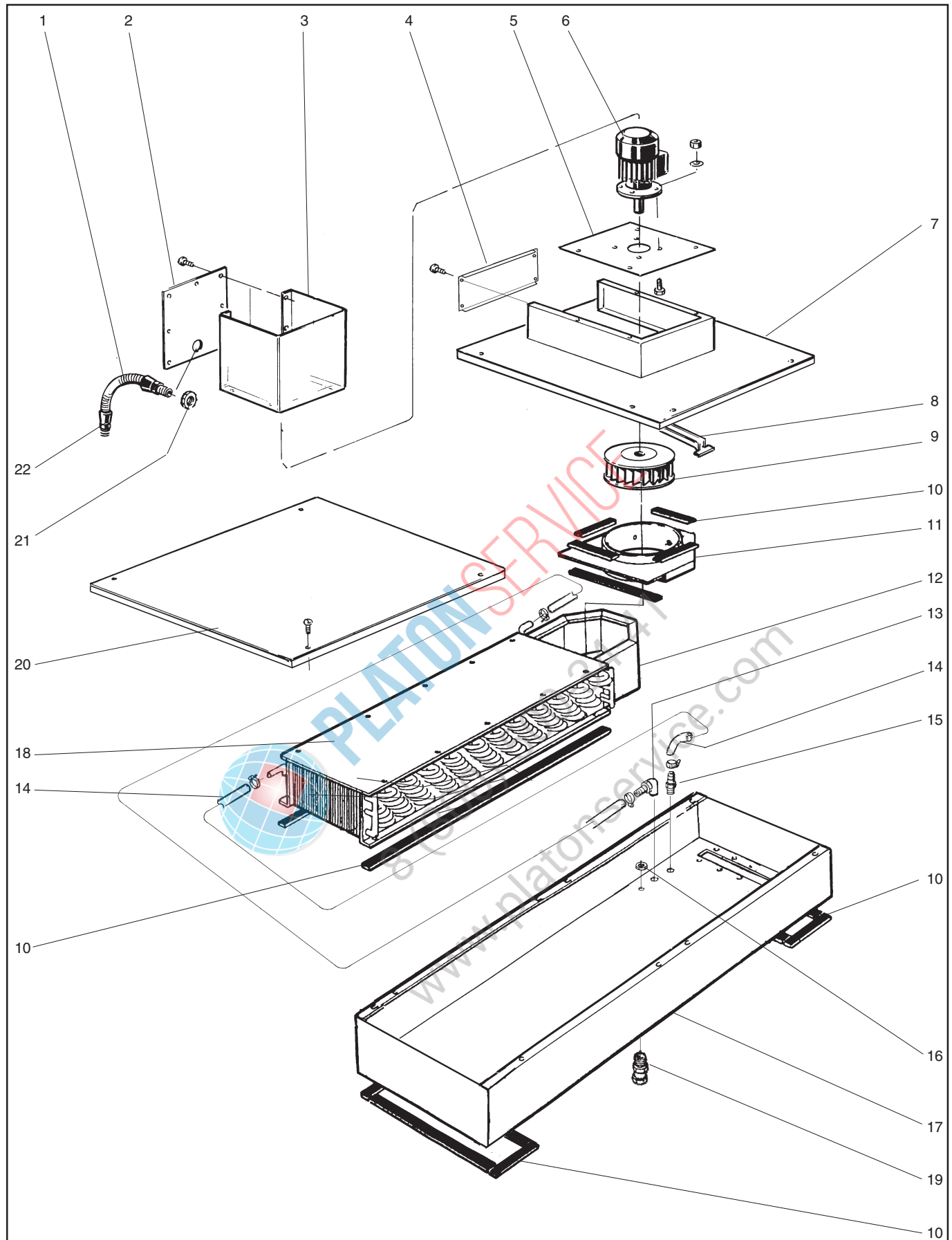

ILLUSTRATION 21638

Kondensbatteri version 2
Condensing unit version 2
Kondensationsbatteri version 2

Illustration 21638

Utgåva
Edition
Ausgabe
4

Månad
Month
Monat
05

År
Year
Jahr
2012

Pos.	Antal Quantity Anzahl	Art.nr Art. no Art. Nr	Benämning	Description	Bezeichnung	Anm. Notes Anm.
1	1	552 00 12-01	Skydds slang	Protective pipe	Schutzschlauch	L=160
2	1	499 82 27-00	Täckplåt	Cover plate	Deckblech	
3	1	499 82 26-00	Takstos	Motor cover	Dach	
4	1	482 55 45-00	Baksida	Rear	Rückseite	
5	1	499 82 24-00	Tak, fläkt	Fan top	Dach	1).
	1	ST0 70 11-00	Tak, fläkt	Fan top	Dach	2).
6	1	499 81 77-01	Fläkt kpl.	Exhausting fan cpl.	Gebläse kpl.	1). 230V, 50Hz
	1	ST0 69 90-00	Fläkt motor	Exhausting fan motor	Gebläse Motor	2). 230V, 50Hz
7	1	499 81 85-00	Fläkt tak	Fan bracket	Geblese dach	
8	2	499 81 02-00	Hållare	Support	Halter	
9	1	549 64 18-00	Fläkthjul	Fan hub	Gebläserad	1).
	1	ST0 28 28-00	Fläkthjul	Fan hub	Gebläserad	2).
10	8m	87 33 03-240	Tätninglist	Sealing strip	Dichtungsleiste	
11	1	482 57 24-00	Takstos	Top	Dach	
12	1	482 57 21-00	Ledplåt	Guiding plate	Führungsblech	
13	1	552 21 73-00	Slangnippel, vinkel	Hose nipple, Angle	Schlauchnippel, Winkel	15X1/2"
14	x	552 00 11-00	Slang	Hose	Schlauch	
15	1	552 21 75-00	Slangnippel	Nipple	Nippel	15X1/2"
16	2	762 11 08-55	Mutter	Nut	Mutter	
17	1	ST0 21 90-00	Kondenslåda	Condensing box	Kondensationskasten	
18	1	482 54 44-00	Lamellelement	Lamellar element	Lamellenelement	
19	1	762 21 08-06	Hylsa	Sleeve	Hülse	Pr 15,2
20	1	ST0 21 93-00	Tak	Top	Dach	
21	4	762 11 09-55	Mutter	Nut	Mutter	Pr 18,6

Fet stil = Ändring

Bold print = Change

Fettdruck = Änderung

1).

2).

T.o.m 2007.52

Fr.o.m 2008.01

To 2007.52

From 2008.01

2007.52

Ab. 2008.01

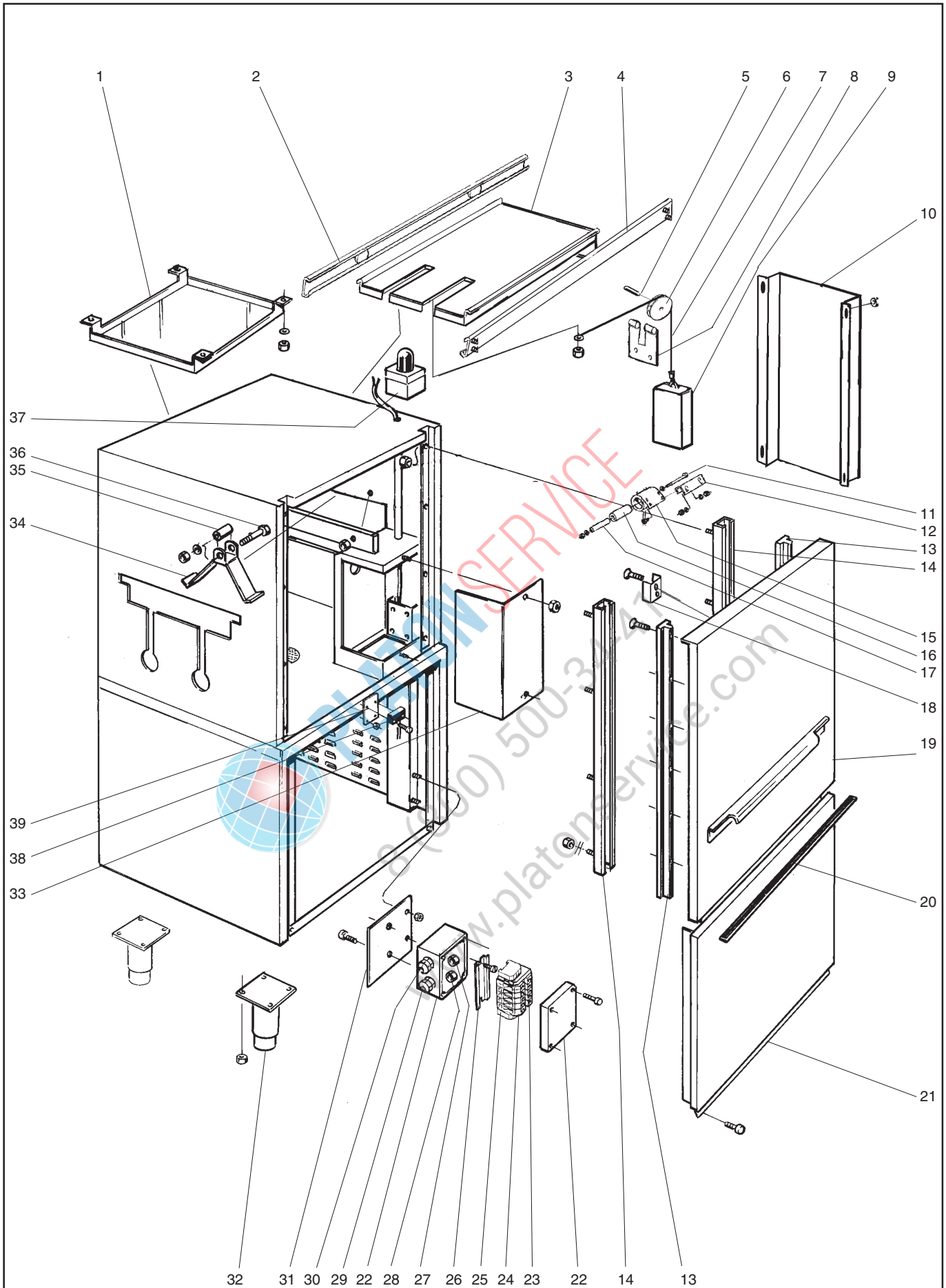

ILLUSTRATION 21634

Torkzon. Drying zone Schrank front			Illustration 21634			Utgåva Edition Ausgabe 5	Månad Month Monat 05	År Year Jahr 2012
Pos.	Antal Quantity Anzahl	Art.nr Art. no Art. Nr	Benämning	Description	Bezeichnung	Anm. Notes Anm.		
1	1	ST0 15 25-00	Droppskydd	Drip guard	Tropfenfänger			
2	1	ST0 24 16-00	Expansionsbeslag Hö	Expansion fittings, right,	Ausdehnungsbeslag, recht	5).		
	1	520 53 20-02	Expansionsbeslag Hö	Expansion fittings, right,	Ausdehnungsbeslag, recht	6).		
3	1	ST0 20 74-00	Ackumuleringsplan	Accumulation plane	Akkumulatorplatte	5).		
	1	ST0 56 45-00	Ackumuleringsplan	Accumulation plane	Akkumulatorplatte	6).		
4	1	ST0 24 15-00	Expansionsbeslag, vä	Expansion fittings, left	Ausdehnungsbeslag, links	5).		
	1	520 53 20-01	Expansionsbeslag, vä	Expansion fittings, left	Ausdehnungsbeslag, links	6).		
5	1	481 72 92-00	Axel	Shaft	Ashe			
6	1	481 71 65-00	Linjehjul	Wheel	Rad			
7	1	ST0 23 97-00	Wire	Wire	Wire	5).		
	1	ST0 56 81-00	Wire	Wire	Wire	6).		
8	1	ST0 21 38-00	Rullfäste	Attachment	Befestigung			
9	1	481 98 62-09	Vikt	Weight	Gewicht			
10	1	ST0 21 25-00	Vikträna	Weight channel	Gewichtsrinne			
11	2	725 24 65-45	Skruv	Screw	Schraube			
12	2	482 45 87-00	Fjäderfäste	Spring retainer	Federträger			
13	2	ST0 14 45-00	Glidlist	Slide strip	Gleitprofil			
14	2	ST0 14 47-00	C-list	C-strip	C-Profil			
15	2	482 25 28-03	Luckfjäder	Spring	Klappenfeder			
16	2	482 25 27-00	Rulle	Pulley	Rolle			
17	2	478 56 10-01	Distans	Spacer	Distanz			
18	1	ST0 15 21-00	Luckstopp	Dorr stop	Tür stopp			
19	1	ST0 14 23-00	Lucka	Door	Tür			
20	x	87 33 30-240	Tättningslist	Sealing strip	Dichtungsleiste			
21	1	ST0 14 59-00	Täckplåt	Cover plate	Deckelplatte			
22	1	491 48 48-00	Kapsling	Casing	Abdeckung	5). SA03525		
	1	ST0 67 10-00	Kapsling	Casing	Abdeckung	6).		
23	7	552 22 50-02	Kopplingsplint Grå4	Block terminal Grey 4	Klemmenbrett Grau 4			
24	1	552 22 54-00	Ändplatta	End palte	Endplatte			
25	2	552 22 55-00	Ändstöd	End support	Stütze			
26	1	475 93 46-03	Monteringsskena	Mounting slide	Montagescheine			
27	2	762 11 09-55	Mutter	Nut	Mutter	Pr 18,6		
28	3	762 11 08-55	Mutter	Nut	Mutter	Pr 15,2		
29	3	762 21 08-06	Genomföring	Inlet	Durchführung	Pr 15,2		
30	2	762 21 09-06	Genomföring	Inlet	Durchführung	Pr 18,6		
31	1	ST0 24 12-00	Konsol	Console	Konsole			
32	4	482 25 52-00	Fot	Foot	Fuss	3).		
	4	855 64 90-00	Fot	Foot	Fuss	4).		
33	1	ST0 15 32-00	Lock kedjeskydd	Lid	Deckel	1).		
	1	ST0 15 32-01	Lock kedjeskydd	Lid	Deckel	2).		
34	1	ST0 15 21-00	Luckstopp	Dorr stop	Türstopp			
35	1	478 56 10-01	Distansrör	Spacer pipe	Distanzrohr			
36	1	725 23 86-40	Skruv	Screw	Schraube			
37	1	ST0 23 98-00	Signallampa	Signal lamp	Kontrollampe			
38	1	476 06 64-01	Signallampa	Signal lamp	Kontrollampe			
39	1	ST0 34 28-00	Signallampa	Signal lamp	Kontrollampe			
			1). Vänstermatad maskin	Left hand feeded machine	Links Richtung			
			2). Högermatad maskin	Right hand feeded machine	Rechts Richtung			
			3). T.o.m 2003.46	To 2003.46	Zu 2003.46			
			4). Fr.o.m 2003.47	From 2003.47	Ab. 2003.47			
			5). T.o.m 2005.52	To 2005.52	Zu 2005.52			
			6). Fr.o.m 2006.01	From 2006.01	Ab. 2006.01			
Fet stil = Ändring								
Bold print = Change								
Fettdruck = Änderung								

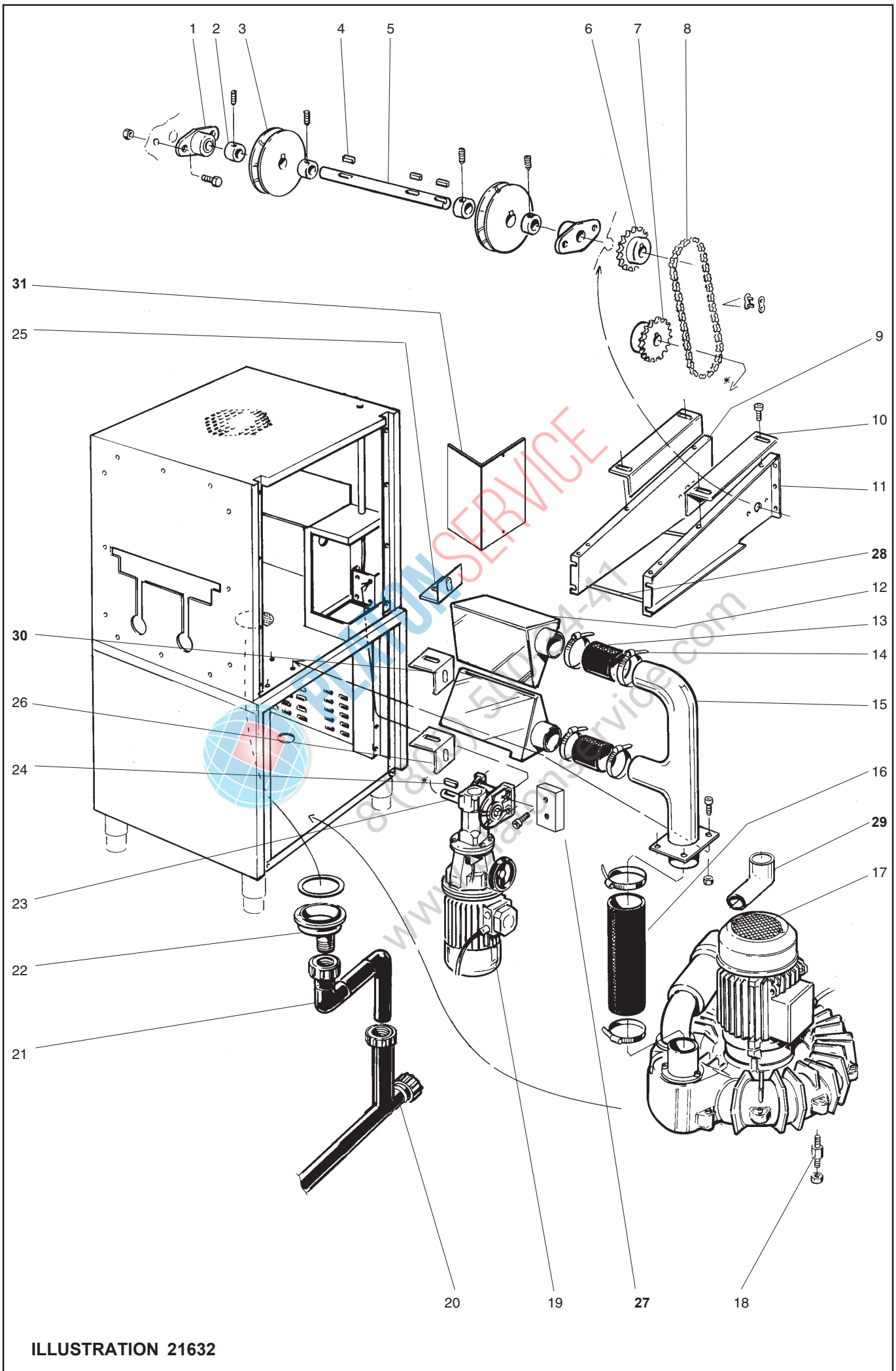

ILLUSTRATION 21632

Torkzon Drying zone Trockenzone			Illustration 21632			Utgåva Edition Ausgabe 4	Månad Month Monat 05	År Year Jahr 2012
Pos.	Antal Quantity Anzahl	Art.nr Art. no Art. Nr	Benämning	Description	Bezeichnung	Anm. Notes Anm.		
1	2	491 35 47-00	Flänslager	Flange bearing	Flanschlager			
2	4	482 37 08-00	Stoppning	Retaining ring	Halterring			
3	2	491 37 12-00	Rundrems hjul	Cord wheel	Rundlaufreimenrad	5).		
	2	ST0 47 05-00	Rundrems hjul	Cord wheel	Rundlaufreimenrad	6).		
4	3	735 92 32-40	Kil	Wedge	Keil			
5	1	428 07 08-00	Matnings axel	Shaft	Achse			
6	1	ST2 03 31-00	Kuggjul	Sprocket	Kettenrad	Z:14		
7	1	491 35 50-00	Kuggjul	Sprocket	Kettenrad	Z:21		
8	1	491 38 33-00	Transmission kedja	Chain	Ketten	1/2" rfr,SS		
9	1	ST0 14 36-00	Matningsgejd Vä	Guide, left	Führungsleiste, links	1).		
	1	ST0 14 37-00	Matningsgejd Hö	Guide, right	Führungsleiste, rechts	2).		
10	2	428 07 41-00	Styrgejd	Guide	Führungsleiste			
11	1	ST0 14 37-00	Matningsgejd Hö	Guide, right	Führungsleiste, links	1).		
	1	ST0 14 36-00	Matningsgejd Vä	Guide, left	Führungsleiste, rechts	2).		
12	2	ST0 14 55-00	Blås	Blower	Gebläse	5).		
	2	ST0 56 52-00	Blås	Blower	Gebläse	6).		
13	2	ST0 24 08-00	Slang	Hose	Schlauch			
14	6	736 28 46-90	Slangklämma	Hose clamp	Schlauchklemme	D= 85		
15	1	ST0 15 22-00	Stamrör	Main conduit	Stammleitung			
16	1	ST0 24 08-01	Slang	Hose	Schlauch			
17	1	ST0 14 27-00	Fläktmotor	Fan motor	Gebläsemotor			
18	3	463 97 78-08	Dämpare	Vibration absorber	Vibrationsdämpfer	5).		
	4	ST0 54 21 00	Dämpare	Vibration absorber	Vibrationsdämpfer	6).		
19	1	520 69 41-00	Motor	Motor	Motor			
20	1	ST0 22 77-00	Avlopp	Drain	Ablauf			
21	1	ST0 24 09-00	Avlopp	Drain	Ablauf			
22	1	476 80 48-00	Silskål	Strainer bowl	Siebschale			
23	1	520 71 25-00	Motoraxel	Motor shaft	Motorachse			
24	1	735 92 35-40	Kil	Wedge	Keil			
25	2	ST0 20 70-00	Fäste, övre	Attachment, upper	Befestigung, über	3).		
	1	ST0 36 58-00	Fäste, övre	Attachment, upper	Befestigung, über	4).		
26	1	ST0 36 57-00	Fäste, undre	Attachment, lower	Befestigung, unter	4).		
27	2	476 80 70-00	Motorfäste	Motor socket	Motorträger			
28	2	ST0 56 49-00	Axel	Shaft	Achse			
29	1	ST0 74 19-00	Vinkel 90°	Elbow pipe 90°	Winkelrohr 90°	2½"		
30	2	ST0 70 09-00	Blåsstopp	Attachment	Befestigung			
31	1	ST0 15 32-00	Lock, kedjkydd vänster	Lid, chane protection, Left	Deckels-, Kettenschutz, Links			
	1	ST0 15 32-01	Lock, kedjkydd Höger	Lid, chane protection, Right	Deckels-, Kettenschutz, Rechts			

Fet stil = Ändring
Bold print = Change
Fettdruck = Änderung

1).	Vänstermatad maskin	Left hand feeded machine	Links Richtung
2).	Högermatad maskin	Right hand feeded machine	Rechts Richtung
3).	Till 2004.39	To 2004.39	Zu 2004.39
4).	Fr.o.m 2004.40	From 2004.40	Ab 2004.40
5).	Till 2008.35	To 2008.35	Zu 2008.35
6).	Fr.o.m 2008.36	From 2008.36	Ab 2008.36

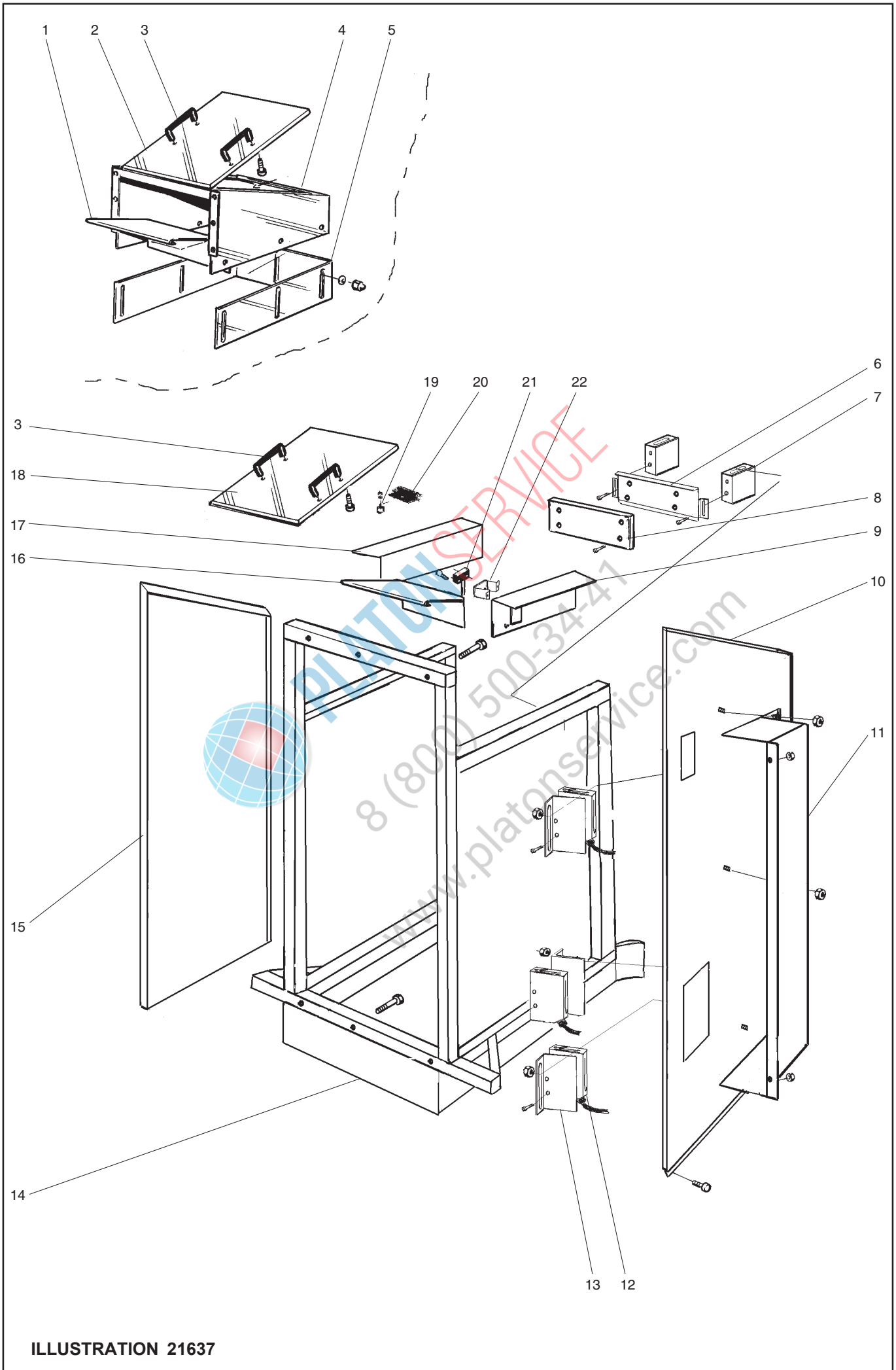

ILLUSTRATION 21637

Brickackumulator Tray accumulator Tablettakkumulator			Illustration 21637			Utgåva Edition Ausgabe 2	Månad Month Monat 05	År Year Jahr 2012
Pos.	Antal Quantity Anzahl	Art.nr Art. no Art. Nr	Benämning	Description	Bezeichnung	Anm. Notes Anm.		
1	1	ST2 10 09-00	Utkastplåt	Utkastplåt	Utkastplåt	Version 1		
2	1	ST0 20 32-00	Lock	Lid	Deckel	Version 1		
3	2	491 39 18-00	Handtag	Handle	Handgriff	Version 1		
4	1	ST0 20 31-00	Utkast	Unloading unit	Führungskasten			
5	1	ST2 10 10-00	Styrkrans	Guiding part	Führungsleiste	Version 1		
6	1	ST0 20 91-00	Brickstopplåt	Tray stop plate	Tablettstopplatta			
7	2	ST0 20 98-00	Styrning	Guide	Führung			
8	1	ST0 21 33-00	Brickstopp	Tray stop	Tablettstopp			
9	1	ST0 21 35-00	Styrplåt vänster	Guide plate, left	Führungsplatte, links	1).		
	1	ST0 21 35-01	Styrplåt vänster	Guide plate, left	Führungsplatte, links	2).		
10	1	ST0 20 77-01	Täckplåt vänster	Cover plate, left	Deckelplatte, links	3).		
	1	ST0 20 78-00	Täckplåt vänster	Cover plate, left	Deckelplatte, links	4).		
11	1	ST0 21 32-00	Kåpa	Casing	Haube			
12	3	491 46 20-00	Fotocell	Fotocell	Fotocell			
13	3	ST0 23 96-00	Fotocellplåt	Fotocell plate	Fotocellplatte			
14	1	ST0 20 76-00	Stativ	Stand	Gestand			
15	1	ST0 20 77-00	Täckplåt höger	Cover plate, right	Coverplatte, recht	3).		
	1	ST0 20 78-01	Täckplåt höger	Cover plate, right	Coverplatte, recht	4).		
16	1	ST0 20 65-00	Kastplåt	Slide plate	Gleitplatte			
17	1	ST0 21 34-00	Styrplåt höger	Guide plate, right	Führungsplatte, recht	1).		
	1	ST0 21 34-01	Styrplåt höger	Guide plate, right	Führungsplatte, recht	2).		
18	1	ST0 20 79-00	Lock	Lid	Deckel			
19	1	461 13 78-02	Magnet	Magnet	Magnet			
20	1	ST0 96 82-00	Magnet fäste	Attachment, magnet	Befestigung Magnet			
21	1	461 06 64-01	Magnetbrytare	Magnetic switch	Magnetausschalter			
22	1	ST0 96 81-00	Fäste	Attachment	Befestigung			

Fet stil = Ändring
Bold print = Change
Fettdruck = Änderung

1).	325 mm breda brickor	325 mm wide trays	325 tablett breite
2).	370 mm breda brickor	370 mm wide trays	370 mm tablett breite
3).	Vänstermatad maskin	Left hand fedded machine	Links Richtung
4).	Högermatad maskin	Right hand fedded machine	Rechts Richtung

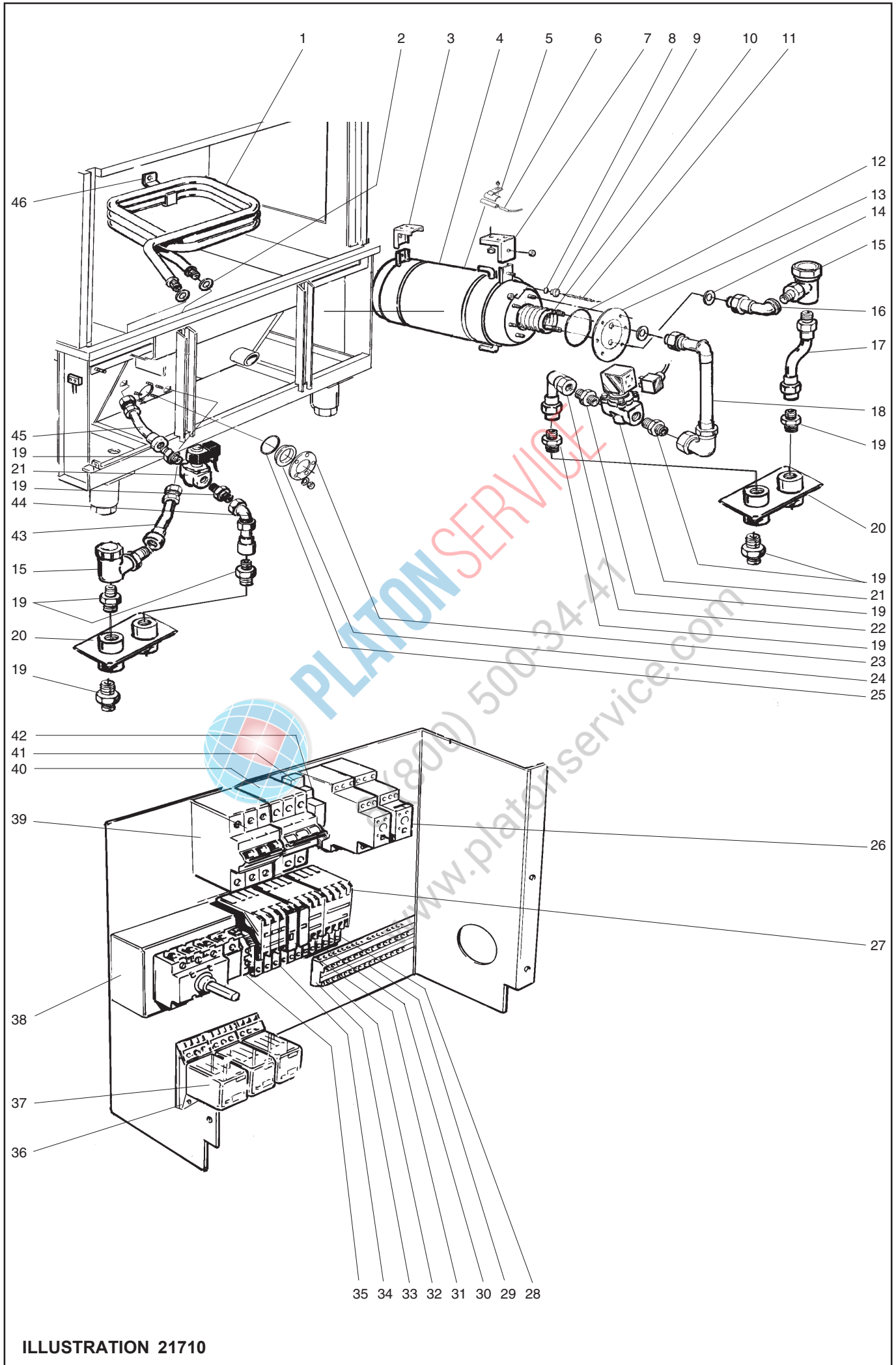

ILLUSTRATION 21710

Ånguppvärmd maskin Steam heated machine Dampfbeheizmaschine	Illustration 21710	Utgåva	Månad	År
	T.o.m. 2011.12.31, valid to 2011.12.31,	Edition	Month	Year
	Gültige bis 2011.12.31	Ausgabe	Monat	Jahr
		2	05	2012

Pos.	Antal Quantity Anzahl	Art.nr Art. no Art. Nr	Benämning	Description	Bezeichnung	Anm. Notes Anm.
1	1	482 47 96-00	Ångslinga	Steam coil	Dampfschleife	
2	2	552 21 10-04	Packning	Gasket	Dichtung	34/27
3	1	482 68 57-00	Fäste bak	Attachment rear	Befestigung	
4	1	482 76 74-01 499 82 56-00	Genomströmmare, kpl. Genomströmmare, kpl.	Booster, cpl. Booster, cpl.	Durchlauferhitzer, Kpl. Durchlauferhitzer, Kpl.	
5	1	552 21 30-00	Termostaffäste	Termost attachment	Termost Befestigung	
6	1	481 84 00-05	Termometer	Thermometer	Thermometer	
7	1	482 68 56-00	Fäste fram	Attachment front	Befestigung	
8	1	740 43 03-14	O-ring	O-ring	O-ring	
9	1	478 04 16-00	Förskruvning	Pipe nipple	Verschraubung	
9,1	2	740 43 03-14	O-ring	O-ring	O-ring	5,3-2,4
9,2	2	482 63 02-00	Bussning	Bush	Buchse	
10	1	491 35 44-00	Ångslinga	Steam coil	Dampfschleife	
11	1	475 77 04-02	Termostat	Thermostat	Thermostat	
12	1	477 74 08-00	Packning	Gasket	Dichtung	
13	1	482 56 80-00 ST2 11 74-00	Fläns Fläns	Flange Flange	Flansch Flansch	
14	1	552 2110-03	Packning	Gasket	Dichtung	
15	1	63 79 74-01	Ångfälla	Steam trap	Kondensfalle	
16	1	ST0 39 58-00	Rör, kpl.	Pipe, cpl.	Rohr, Kpl.	
17	1	ST0 39 60-00	Rör, kpl.	Pipe, cpl.	Rohr, Kpl.	
18	1	ST0 39 59-00	Rör, kpl.	Pipe, cpl.	Rohr, Kpl.	
19	10	741 31 15-22	Nippel	Nipple	Nippel	3/4"-3/4"
20	1	499 82 55-00	Fäste	Bracket	Befestigung	
21	1	482 17 40-03	Magnetventil	Solenoid valve	Magnetventil	50 Hz
22	1	ST0 39 58-00	Rör, kpl.	Pipe, cpl.	Rohr, Kpl.	
23	1	478 08 59-00	Elementfläns	Element flange	Körperflansche	
24	1	482 47 94-00	Lock	Lid	Deckel	
25	1	740 48 31-05	O-ring	O-ring	O-ring	
26	1	552 22 20-00	Tidrelä	Time relay	Zeitrelais	3).
	1	ST0 12 42-00	Tidrelä	Time relay	Zeitrelais	4).
27	3	767 51 14-09	Kontaktor K1,K4,K7	Contactor K1,K4,K7	Kontaktor K1,K4,K7	3).
	3	ST0 27 90-03	Kontaktor K1,K4,K7	Contactor K1,K4,K7	Kontaktor K1,K4,K7	4).
28	1	767 61 12-00	Överströmsrelä N7	Overload protection N7	Überlastungsschutz N7	3). 8-11 A
	1	ST0 28 54-12	Överströmsrelä N7	Overload protection N7	Überlastungsschutz N7	4). 8-11 A
29	37	552 22 50-02	Kopplinsplint Grå 4	Terminal block Gray 4	Klemmenbrett	
30	1	767 61 10-00	Överströmsrelä N4	Overload protection N4	Überlastungsschutz N4	3). 4-6 A
	1	ST0 28 54-10	Överströmsrelä N4	Overload protection N4	Überlastungsschutz N4	4). 4-6 A
31	1	767 51 01-92	Hjälpkontakt block	Support contact block	Hilfskontaktblech	NO grön, green

Fet stil = Ändring
Bold print = Change
Fettdruck = Änderung

1). TW1
2). ZTW1
3). T.o.m. 2004.10 To 2004.10 Zu 2004.10
4). Fr.o.m. 2004.11 From 2004.11 Ab. 2004.11

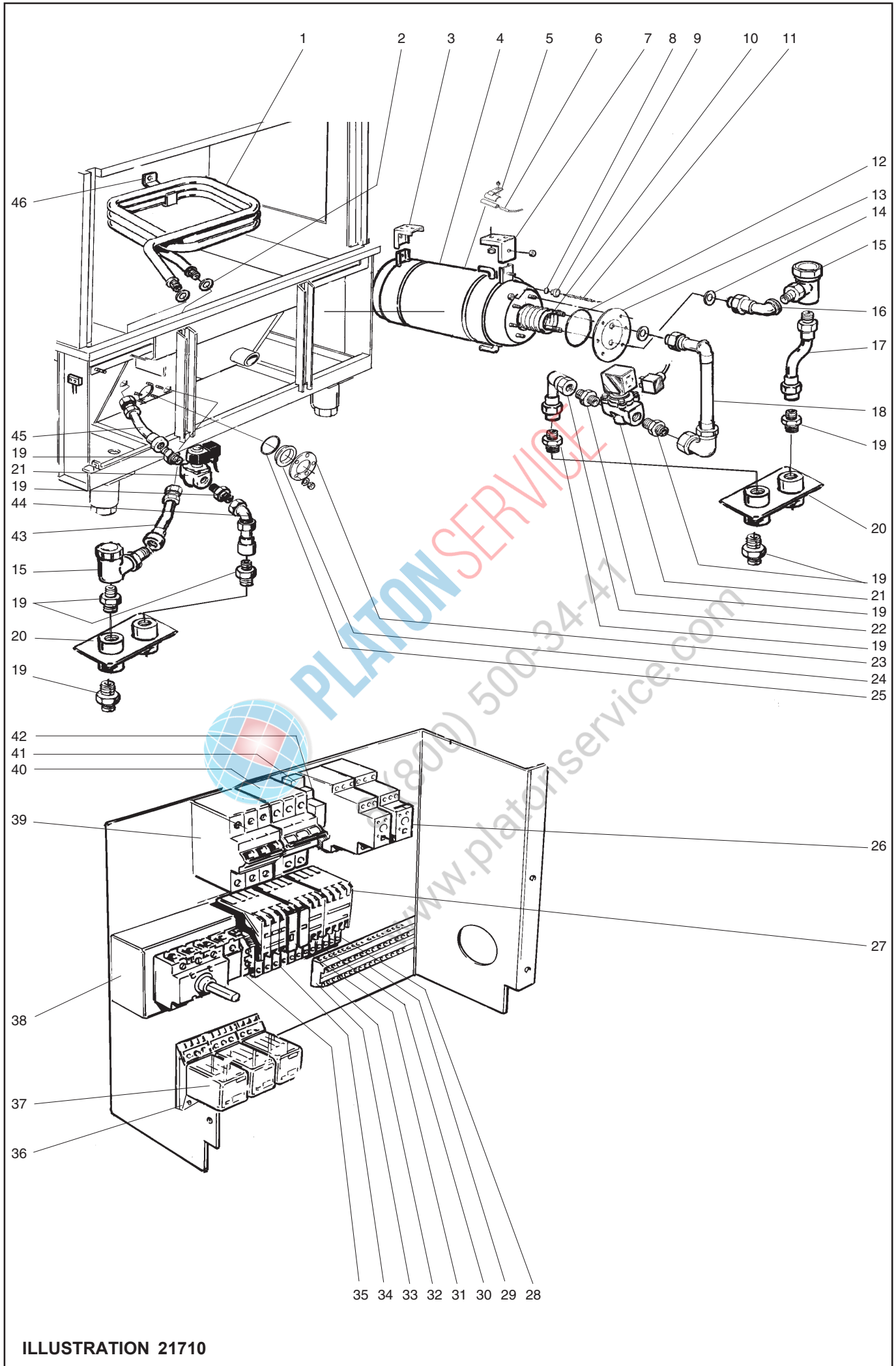

ILLUSTRATION 21710

Ånguppvärmd maskin
Steam heated machine
Dampfbeheizmaschine

Illustration 21710

T.o.m. 2011.12.31,
valid to 2011.12.31,
Gültige bis 2011.12.31

Utgåva
Edition
Ausgabe
2

Månad
Month
Monat
05

År
Year
Jahr
2012

Pos.	Antal Quantity Anzahl	Art.nr Art. no Art. Nr	Benämning	Description	Bezeichnung	Anm. Notes Anm.
32	2	552 22 54-00	Ändplatta	End plate	Endplatte	
33	4	552 22 55-00	Ändstöd	End support	Stütze	
34	1	767 61 06-00	Överströmsrelä N1	Overload protection N1	Überlastungsschutz N1	3). 0,8-1,2 A
	1	ST0 28 54-06	Överströmsrelä N1	Overload protection N1	Überlastungsschutz N1	3). 0,8-1,2 A
35	1	552 22 52-06	Kopplinsplint Gul/grön 35	Terminal block Yellow/Green 35	Klemmenbrett Gelb/Grün 35	
36	1	552 21 22-00	Socket 3 pol	Base	Socket	
37	1	552 21 22-01	Relä 3 pol	Relay	Zeitrelais	
38	1	491 45 73-00	Brytare	Switch	Schalter	80A
39	1	552 22 23-20	Automatsäkring F1	Automatic fuse F1	Automatsicherung F1	3). 20A
	1	552 22 23-16	Automatsäkring F1	Automatic fuse F1	Automatsicherung F1	4). 16A
40	1	552 22 23-10	Automatsäkring F5	Automatic fuse F5	Automatsicherung F5	3). 10A
	1	552 22 23-16	Automatsäkring F5	Automatic fuse F5	Automatsicherung F5	4). 16A
41	1	552 21 23-00	Socket 1 pol	Base	Socket	
42	1	552 21 23-01	Relä 1 pol	Relay	Zeitrelais	
43	1	499 81 56-00	Rör, kpl.	Pipe, cpl.	Rohr, Kpl.	
44	1	499 81 58-00	Rör, kpl.	Pipe, cpl.	Rohr, Kpl.	
45	1	499 81 57-00	Rör, kpl.	Pipe, cpl.	Rohr, Kpl.	
46	1	482 73 80-00	Hållare	Holder	Halter	



- 1). TW1
2). ZTW1
3). T.o.m. 2004.10
4). Fr.o.m. 2004.11

Fet stil = Ändring
Bold print = Change
Fettdruck = Änderung

To 2004.10
From 2004.11
Zu 2004.10
Ab. 2004.11

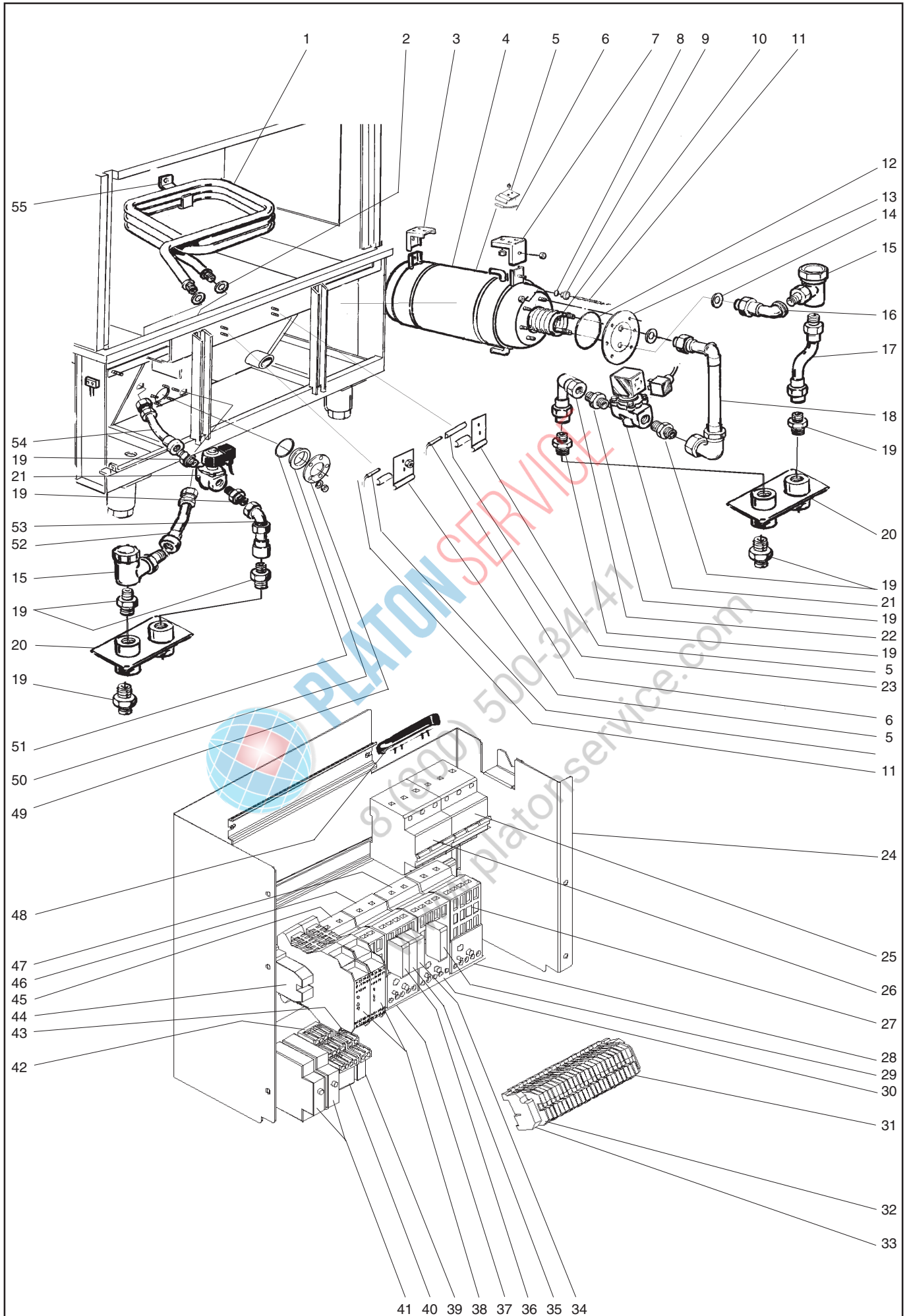

ILLUSTRATION 21646

Ånguppvärmd maskin Steam heated machine Dampfheizmaschine			Illustration 21646 Fr.o.m. 2012.01.01, valid from 2012.01.01, Gilt vom 2012.01.01			Utgåva Edition Ausgabe 3	Månad Month Monat 03	År Year Jahr 2013
Pos.	Antal Quantity Anzahl	Art.nr Art. no Art. Nr	Benämning	Description	Bezeichnung	Anm. Notes Anm.		
1	1	482 47 96-00	Ångslinga	Steam coil	Dampfschleife			
2	2	552 21 10-04	Packning	Gasket	Dichtung	34/27		
3	1	482 68 57-00	Fäste bak	Attachment rear	Befestigung			
4	1	482 76 74-01	Genomströmmare, kpl.	Booster, cpl.	Durchlauferhitzer, Kpl.			
5	2	552 21 30-00	Termostatfäste	Thermost attachment	Thermost Befestigung			
6	1	481 84 00-05	Termometer	Thermometer	Thermometer			
7	1	482 68 56-00	Fäste fram	Attachment front	Befestigung			
8	1	740 43 03-14	O-ring	O-ring	O-ring			
9	1	478 04 46-00	Förskruvning	Pipe nipple	Verschraubung			
10	1	491 35 44-00	Ångslinga	Steam coil	Dampfschleife			
11	2	475 77 04-02	Termostat	Thermostat	Thermostat			
12	1	477 74 08-00	Packning	Gasket	Dichtung			
13	1	482 56 80-00	Fläns	Flange	Flansch			
		ST2 11 74-00	Fläns	Flange	Flansch			
14	1	552 2110-03	Packning	Gasket	Dichtung			
15	1	63 79 74-01	Ångfälla	Steam trap	Kondensfalle			
16	1	ST0 39 58-00	Rör, kpl.	Pipe, cpl.	Rohr, Kpl.			
17	1	ST0 39 60-00	Rör, kpl.	Pipe, cpl.	Rohr, Kpl.			
18	1	ST0 39 59-00	Rör, kpl.	Pipe, cpl.	Rohr, Kpl.			
19	10	741 31 15-22	Nippel	Nipple	Nippel	3/4"-3/4"		
20	2	499 82 55-00	Fäste	Bracket	Befestigung			
21	2	482 17 40-03	Magnetventil	Solenoid valve	Magnetventil	50 Hz		
22	1	ST0 39 58-00	Rör, kpl.	Pipe, cpl.	Rohr, Kpl.			
23	1	482 60 19-00	Halvrund hylsa	Semicircular sleeve	Halbrunde Hülse			
24	1	ST0 96 03-00	Elplåt	Connection plate	Anschlussblech			
25	1	552 22 23-10	Automatsäkring F5	Automatic fuse F5	Automatsicherung F5	10A		
26	1	552 22 23-20	Automatsäkring F1	Automatic fuse F1	Automatsicherung F1	20A		
27	1	ST0 27 90-03	Kontaktor K7	Contactactor K7	Kontaktor K7			
28	1	ST0 28 54-12	Överströmsrelä N7	Overload protection N7	Überlastungsschutz N7	8-11 A		
29	1	767 51 01-92	Hjälpkontakt block	Support contact block	Hilfskontaktblech	NO,	HN10	
30	1	ST0 28 54-10	Överströmsrelä N4	Overload protection N4	Überlastungsschutz N4	4-6 A		
31	29	552 22 50-02	Kopplinsplint Grå 4	Terminal block Gray 4	Klemmenbrett Grau 4			
32	2	552 22 54-00	Ändplatta	End plate	Endplatte			
33	4	552 22 55-00	Ändstöd	End support	Stütze			
34	1	767 51 01-92	Hjälpkontakt block	Support contact block	Hilfskontaktblech	NO,	HN10	
35	1	767 51 01-92	Hjälpkontakt block	Support contact block	Hilfskontaktblech	NC,	HN01	
36	1	767 51 01-92	Hjälpkontakt block	Support contact block	Hilfskontaktblech	NC,	HN01	
37	1	ST0 28 54-06	Överströmsrelä N1	Overload protection N1	Überlastungsschutz N1	0,8-1,2 A		

Fet stil = Ändring
Bold print = Change
Fettdruck = Änderung

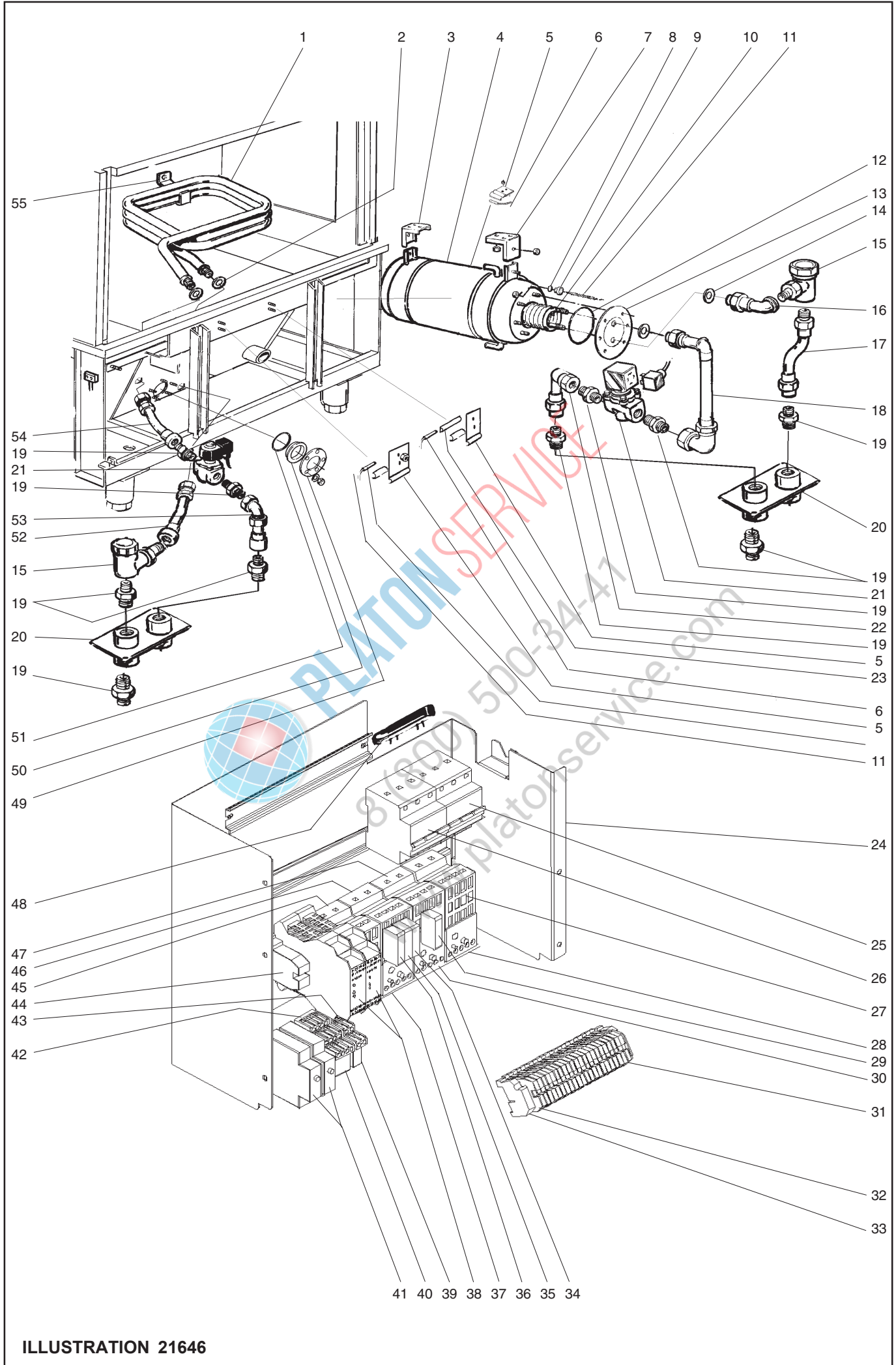

ILLUSTRATION 21646

Ånguppvärmd maskin
Steam heated machine
Dampfbeheizmaschine

Illustration 21646

Fr.o.m. 2012.01.01,
valid from 2012.01.01,
Gilt vom 2012.01.01

Utgåva
Edition
Ausgabe
3

Månad
Month
Monat
03

År
Year
Jahr
2013

Pos.	Antal Quantity Anzahl	Art.nr Art. no Art. Nr	Benämning	Description	Bezeichnung	Anm. Notes Anm.
38	2	ST0 93 13-00	Säkerhetsrelä	Safety relay	Sicherheitsrelais	24V AC/DC 2 pol
39	1	ST0 93 87-10	Socket	Base	Socket	
40	1	ST0 93 87-10	Socket	Base	Socket	4 pol
41	2	ST0 12 42-00	Tidrelä	Time relay	Zeitrelais	
42	1	ST0 93 86-00	Relä	Relay	Zeitrelais	4 pol VAC 2 pol
43	1	ST0 93 86-10	Relä	Relay	Zeitrelais	
44	1	552 22 52-06	Kopplingsplint Gul/grön 35	Terminal block Yellow/Green 35	Klemmenbrett Gelb/Grün 35	
45	1	ST0 27 90-12	Kontaktor K3	Contactor K3	Kontaktor K3	
46	1	ST0 27 90-03	Kontaktor K1	Contactor K1	Kontaktor K1	
47	1	ST0 27 90-03	Kontaktor K4	Contactor K4	Kontaktor K4	
48	1	552 55 08-02	Fasskena	Phase bar	Phasenscheine	
49	1	478 08 59-00	Elementfläns	Element flange	Körperflansche	
50	1	482 47 94-00	Lock	Lid	Deckel	
51	1	740 48 31-05	O-ring	O-ring	O-ring	
52	1	499 81 56-00	Rör, kpl.	Pipe, cpl.	Rohr, Kpl.	
53	1	499 81 58-00	Rör, kpl.	Pipe, cpl.	Rohr, Kpl.	
54	1	499 81 57-00	Rör, kpl.	Pipe, cpl.	Rohr, Kpl.	
55	1	482 73 80-00	Hållare	Holder	Halter	



PLATON SERVICE
8 (800) 500-34-47
www.platonservice.com

Fet stil = Ändring
Bold print = Change
Fettdruck = Änderung

Fästelement Attachment element Befestigungsteile				Utgåva Edition Ausgabe 2	Månad Month Monat 05	År Year Jahr 2012
Art.nr Art. no Art. Nr	Benämning	Description	Bezeichnung	Anm. Notes Anm.		
552 20 25-00 552 21 21-02	Korgmutter Flänsmutter	Cage nut Flange nut	Korbmutter Flanschmutter	M5 M5		
53 92 88-32 53 92 88-51 722 78 43-02	Bricka Bricka Popnit	Washer Washer Blind rivet	Scheibe Scheibe Popniete	BRB 6,4x38 RFR BRB 8,5x38 RFR 4x10,3		
732 31 14-40 732 31 16-40	Kupolmutter Mutter	Dome nut Nut	Kappenmutter Mutter	MHM 5 RFR MHM 6 RFR		
736 28 28-51 736 28 43-90 736 28 55-90	Slangklämma Slangklämma Slangklämma	Hose clamp Hose clip Hose clip	Schlauchklemme Schlauchschelle Schlauchschelle	Ø 38 Ø 75 Ø 138		
478 56 64-03 725 53 29-40	Skruv Skruv	Screw Screw	Schraube Schraube	LKCS 5x10 RFR MC6S 5x16 RFR		
725 54 51-40 728 83 21-09 728 84 47-09	Skruv Skruv Skruv	Screw Screw Screw	Schraube Schraube Schraube	MC6S 8x20 RFR SK6SS 5x6 RFR SK6SS 8x12 RFR		
734 11 24-09 734 11 36-09 734 48 84-40 734 11 46-09	Bricka Bricka Bricka Bricka	Washer Washer Washer Washer	Scheibe Scheibe Scheibe Scheibe	BRB 3,2x7 RFR BRB 4,3x9 RFR BRB 5,2x15 RFR BRB 5,3x10 RFR		
734 49 17-40 734 11 64-09 734 11 73-09	Bricka Bricka Bricka	Washer Washer Washer	Scheibe Scheibe Scheibe	BRB 6,5x16 RFR BRB 8,4x25 RFR BRB 10,5x21 RFR		
734 11 78-09 724 12 28-40	Bricka Skruv	Washer Screw	Scheibe Schraube	BRB 13x24 RFR MRX 3x16 RFR		
724 12 89-40 724 12 92-40 724 13 23-40	Skruv Skruv Skruv	Screw Screw Screw	Schraube Schraube Schraube	MRX 4x10 RFR MRX 4x14 RFR MRX 5x8 RFR		
724 13 31-40 725 23 27-40 725 23 31-40	Skruv Skruv Skruv	Screw Screw Screw	Schraube Schraube Schraube	MRX 5x20 RFR M6S 5x12 RFR M6S 5x20 RFR		
725 23 66-40 725 23 70-40 725 23 78-40	Skruv Skruv Skruv	Screw Screw Screw	Schraube Schraube Schraube	M6S 6x12 RFR M6S 6x20 RFR M6S 6x40 RFR		
725 24 49-40 725 24 53-40 725 24 69-40	Skruv Skruv Skruv	Screw Screw Screw	Schraube Schraube Schraube	M6S 8x16 RFR M6S 8x25 RFR M6S 8x90 RFR		
725 24 95-40 725 25 11-40	Skruv Skruv	Screw Screw	Schraube Schraube	M6S 10x30 RFR M6S 10x100 RFR		
731 23 10-40 731 23 12-40 731 23 16-40	Mutter Mutter Mutter	Nut Nut Nut	Mutter Mutter Mutter	M6M 3 RFR M6M 4 RFR M6M 6 RFR		
731 23 18-40	Mutter	Nut	Mutter	M6M 8 RFR		
731 23 20-40	Mutter	Nut	Mutter	M6M 10 RFR		
735 11 36-40 735 11 46-40 735 11 53-40	Fjäderbricka Fjäderbricka Fjäderbricka	Elastic washer Elastic washer Elastic washer	Federscheibe Federscheibe Federscheibe	FBB 4,1 RFR FBB 5,1 RFR FBB 6,1 RFR		
735 11 64-40 735 11 73-40	Fjäderbricka Fjäderbricka	Elastic washer Elastic washer	Federscheibe Federscheibe	FBB 8,2 RFR FBB 10.2 RFR		

Fet stil = Ändring

Bold print = Change

Fettdruck = Änderung

Fästelement Attachment element Befestigungsteile				Utgåva Edition Ausgabe 2	Månad Month Monat 05	År Year Jahr 2012
Art.nr Art. no Art. Nr	Benämning	Description	Bezeichnung	Anm. Notes Anm.		
724 32 87-40	Skruv	Screw	Schraube	MFX 4x8 RFR		
724 32 93-40	Skruv	Screw	Schraube	MFX 4x16 RFR		
724 33 31-40	Skruv	Screw	Schraube	MFX 5x12 RFR		
724 33 35-40	Skruv	Screw	Schraube	MFX 5x30 RFR		
724 33 64-40	Skruv	Screw	Schraube	MFX 6x10 RFR		



PLATON SERVICE
8 (800) 500-34-41
www.platonservice.com

Fet stil = Ändring
Bold print = Change
Fettdruck = Änderung

